



---

# An Introduction to Solar Collectors for Heating and Cooling of Buildings and Domestic Hot Water

By

J. Paul Guyer, P.E., R.A.

8 PDH HOURS

---

# An Introduction to Solar Collectors for Heating and Cooling of Buildings and Domestic Hot Water Heating



## **GUYER PARTNERS**

44240 Clubhouse Drive  
El Macero, CA 95618  
(530) 758-6637  
jpguyer@pacbell.net

## **J. PAUL GUYER, P.E., R.A.**

Paul Guyer is a registered civil engineer, mechanical engineer, fire protection engineer and architect with over 35 years experience designing all types of buildings and related infrastructure. For an additional 9 years he was a public policy advisor on the staff of the California Legislature dealing with infrastructure issues. He is a graduate of Stanford University and has held numerous local, state and national offices with the American Society of Civil Engineers and National Society of Professional Engineers. He is a Fellow of the American Society of Civil Engineers and the Architectural Engineering Institute.

# CONTENTS

1. INTRODUCTION
  - 1.1 SCOPE
  - 1.2 RELATED CRITERIA
  - 1.3 SOLAR ENERGY
2. FLAT PLATE SOLAR COLLECTORS
  - 2.1 COLLECTORS
  - 2.2 ENERGY STORAGE AND AUXILIARY HEAT
  - 2.3 DOMESTIC HOT WATER SYSTEMS (DHW)
  - 2.4 THERMOSYPHON, BATCH AND INTEGRAL COLLECTOR SYSTEMS
  - 2.5 SPACE HEATING AND DHW SYSTEMS
  - 2.6 PASSIVE SYSTEMS
  - 2.7 SOLAR COOLING SYSTEMS
  - 2.8 SYSTEM CONTROLS

This course is adapted from the *Unified Facilities Criteria* of the United States government, which is in the public domain, has unlimited distribution and is not copyrighted.

The Figures, Tables and Symbols in this document are in some cases a little difficult to read, but they are the best available. **DO NOT PURCHASE THIS COURSE IF THE FIGURES, TABLES AND SYMBOLS ARE NOT ACCEPTABLE TO YOU.**

## 1. INTRODUCTION

**1.1 SCOPE.** This course presents design criteria and cost analysis methods for the sizing and justification of solar heat collectors for potable water and space heaters. Information is presented to enable engineers to understand solar space conditioning and water heating systems or conduct feasibility studies based on solar collector performance, site location, and economics. Both retrofit and new installations are considered.

**1.2 RELATED CRITERIA.** Standards and performance criteria relating to solar heating systems have been evolved by government agencies and various associations and institutes. The most widely used are listed below. Because solar technology is a continuously evolving field, be aware that publications listed below may have been revised or superseded.

<u>Subject</u>	<u>Document</u>
Solar Collector Instantaneous Performance	ASHRAE Standard 93-77, "Methods of Testing to Determine the Thermal Performance of Solar Collectors"
Thermal Storage Devices	ASHRAE Standard 94-77, "Methods of Testing Thermal Storage Devices Based on Thermal Performance"
Complete Solar Collector Performance Evaluation	National Bureau of Standards, NBSIR 78-1305A, "Provisional Flat Plate Solar Collector Testing Procedures: First Revision"
Testing Solar Hot Water Heaters (includes Thermosyphon, Batch, Breadbox, or Integral Storage Collectors)	ASHRAE Standard 95-81, "Methods of Testing to Determine the Thermal Performance of Solar Domestic Water Heating Systems"
Testing Swimming Pool Solar Collectors	ASHRAE Standard 98-80, "Methods of Testing to Determine the Thermal Performance of Unglazed Flat-Plate Liquid Solar Collectors"

Testing Tracking Concentrator Collectors	Solar Energy Industries Association, "Methodology for Determining the Thermal Performance Rating for Tracking Concentrator Solar Collectors"
Solar System Performance	National Bureau of Standards, NBSIR 76-1187, "Interim Performance Criteria for Solar Heating and Cooling Systems in Commercial Buildings"
Property Standards for Solar Systems	HUD Report 4930.2, "Intermediate Minimum Property Standards Supplement, Solar Heating and Domestic Hot Water Systems"
Property Standards Developed for HUD Domestic Hot Water Initiative	National Bureau of Standards, NBSIR 77-1272, "Intermediate Standards for Solar Domestic Hot Water Systems/HUD Initiative"
Solar Collector Certification and Labeling	ARI Standard 910, "The Air Conditioning and Refrigeration Institute (ARI) Certification Program for Solar Collectors"
Solar Collector Certification, Rating, and Labeling	Solar Energy Industries Association Standard, Directory of SRCC Certified Solar Collector Ratings
Building Code	Council of American Building Officials DOE/CS/34281-01, "Recommended Requirements to Code Officials for Solar Heating, Cooling, and Hot Water Systems"
Overall Standards Summary	National Bureau of Standards, NBSIR 78-1143A, "Plan for the Development and Implementation of Standards for Solar Heating and Cooling Applications"; or "ASTM Standards on Solar Energy", ASTM Committee E-44
Installation Guidelines	National Bureau of Standards, NBS Tech. Note 1134, "Guidelines for the Installation of Solar Components on Low Sloped Roofs"; and Dept. of Energy,

	<p>"Installation Guidelines for Solar DHW Systems in One and Two-Family Dwellings"; and National Bureau of Standards, NBSIR 80-2116, "Dimensional Considerations in Solar Installations"; and Sheet Metal and Air Conditioning Contractor National Association, Inc., "Installation Standards for One and Two-Family Dwellings and Multifamily Housing Including Solar"</p>
Solar Materials and Components	<p>Dept. of Energy, DOE/TIC-11374 "Solar Heating Materials Handbook"; and National Bureau of Standards Technical Note 1132, "Solar Energy Systems - Standards for Cover Plates for Flat Plate Collectors"; and National Bureau of Standards, NBSIR 79-1913, "Solar Energy Systems - Standards for Rubber Hose"; and National Bureau of Standards, NBSIR 81-2232, "Solar Energy Systems - Standards for Absorber Materials"</p>
Miscellaneous Tests	<p>National Bureau of Standards, NBSIR 81-2344, "Fire Testing of Roof-Mounted Solar Collectors by ASTM E108"; and National Bureau of Standards, NBSIR 81-2199, "Wind, Earthquake, Snow, and Hail Loads on Solar Collectors"; and NBSIR 82-2487, "Hail Impact Testing Procedures for Solar Collector Covers"</p>
Product Safety	<p>National Bureau of Standards, NBSIR78- (See also HUD Report 4930.2) 1532, "Environmental and Safety Considerations for Solar Heating and Cooling Applications"</p>
Certified Test Labs	<p>National Bureau of Standards, NBSIR</p>

In addition to these standards, there are plumbing standards published by The International Association of Mechanical and Plumbing Officials (IAMPO), and various state building codes.

### **1.3 SOLAR ENERGY.**

**1.3.1 SOLAR RADIATION.** Energy from the sun is received by the earth as electromagnetic radiation. Most of the energy is received in the visible and infrared portions and a small amount as ultraviolet radiation. North of the Tropic of Cancer (23 deg. N latitude), the sun makes a daily arc across the southern sky from east to west as shown in Figure 1-1. For a typical location at 32 deg. N latitude the sun would be 81.5 deg. above the southern horizon or nearly overhead at noon (solar time) on June 21 while on December 21 it would be only 34.6 deg. above the horizon. Solar insolation (I) is measured in Langleys (L) or Btu/ft<sup>2</sup>. One Langley equals 3.688 Btu/ft<sup>2</sup>. The amount of solar energy that exists outside the atmosphere, often called the solar constant, is 116.4 L/hr or 429.2 Btu/ ft<sup>2</sup>-hr. At most 70% to 80% of this amount will strike the earth's surface, the remainder being absorbed or reflected in the atmosphere.

Monthly average and yearly average daily insolation data for numerous locations are given in Table 1-1. In general, the higher the latitude, the less insolation is received on a horizontal surface.

**1.3.2 COLLECTING SOLAR ENERGY.** Collection of solar energy is based on the very high absorption of radiant energy by dull, black surfaces and on the "greenhouse effect." The latter refers to the ability of glass to transmit visible radiation but prevent the loss of heat from the collector plate which radiates at longer wavelengths (infrared frequencies). Glass (or plastic) cover plates are generally used over flat absorber plates to reduce heat loss (see Figure 1-2). The heated absorber plate may have a fluid (water, air or other) pass over it or through tubes attached to the plate. The fluid thus

heated may be used to heat potable water, heat spaces, or drive an absorption or Rankine power cycle air conditioner.

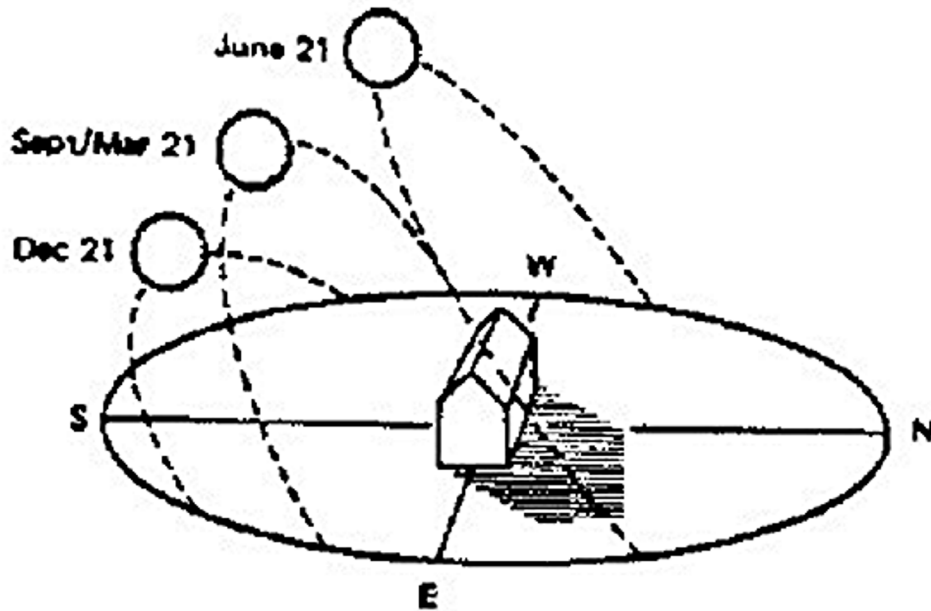

Figure 1-1

The sun's path across the sky at specific times of year

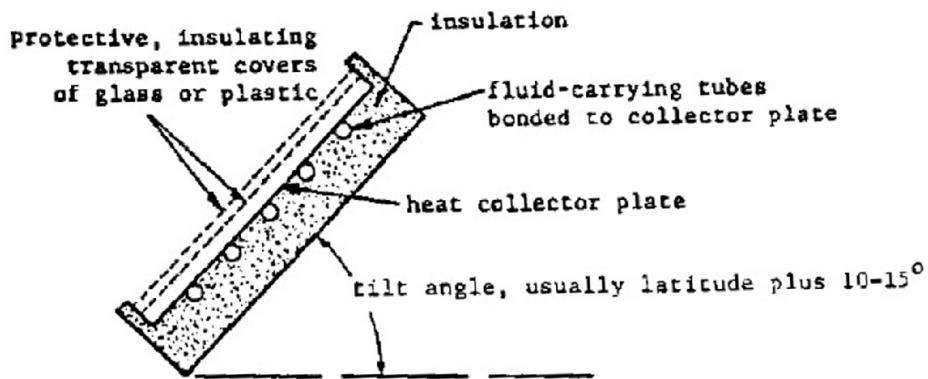

Figure 1-2

Schematic cross-section of typical solar collector with heavy black insulation and two cover sheets



STATE AND STATION	LATITUDE	JAN	FEB	MAR	APR	MAY	JUN	JUL	AUG	SEP	OCT	NOV	DEC	ANNUAL
ALABAMA														
Birmingham	33°34'N	706.6	967.1	1296.3	1673.5	1856.9	1918.5	1809.8	1723.8	1454.6	1210.8	857.9	661.4	1340.7
Mobile	30°41'N	828.2	1098.6	1407.5	1721.7	1872.1	1868.5	1715.3	1641.5	1449.6	1288.7	955.1	750.2	1384.7
Montgomery	32°18'N	751.7	1013.0	1340.6	1728.9	1897.4	1972.3	1841.0	1745.7	1467.7	1266.6	935.4	719.4	1387.9
ALASKA														
Adak	51°53'N	231.2	432.6	716.4	1032.6	1379.6	1382.0	1120.4	948.6	759.3	528.2	308.0	187.7	718.8
Annette	55° 2'N	177.9	374.7	717.1	1149.5	1475.1	1465.6	1439.2	1162.3	812.2	422.2	218.6	122.5	794.6
Barrow	71°18'N	0.0	73.8	490.5	1050.2	1340.0	1527.5	1459.1	855.8	414.3	125.7	1.6	0.0	595.0
Fairbanks	64°49'N	30.1	221.4	674.7	1393.9	1603.6	1751.9	1542.5	1118.0	709.4	292.6	74.1	2.5	747.8
Kodiak	57°45'N	149.3	355.9	741.9	1207.8	1376.3	1529.9	1408.2	1164.2	794.0	489.2	206.5	97.1	796.7
ARIZONA														
Phoenix	33°26'N	1021.0	1374.1	1814.1	2354.8	2676.5	2739.2	2486.5	2292.6	2015.4	1576.5	1150.5	932.0	1869.4
Tucson	32° 7'N	1090.0	1437.0	1864.3	2367.0	2675.4	2729.6	2343.1	2187.9	1978.8	1601.9	1208.4	995.8	1877.3
Yuma	32°40'N	1046.1	1443.2	1919.2	2412.8	2728.3	2813.9	2453.4	2379.3	2051.0	1622.8	1214.7	1000.1	1923.7
ARKANSAS														
Fort Smith	35°20'N	743.7	998.9	1311.7	1635.9	1912.1	2089.4	2065.3	1877.4	1501.5	1200.7	851.4	681.4	1409.3
Little Rock	34°44'N	733.3	1002.8	1312.7	1610.7	1929.3	2106.5	2032.3	1869.5	1518.0	1228.3	887.2	673.7	1404.4
CALIFORNIA														
Bakersfield	35°25'N	746.4	1101.9	1594.8	2094.7	2509.1	2749.3	2683.5	2420.7	1991.8	1438.3	947.3	677.4	1749.2
China Lake	35°41'N	909.4	1229.5	1734.9	2233.5	2548.5	2746.8	2612.2	2415.9	1979.7	1472.6	1033.7	840.8	1829.8
Daggett	34°52'N	938.2	1280.7	1772.3	2274.1	2593.2	2766.3	2603.4	2382.6	2007.9	1515.6	1089.1	826.0	1842.8
El Toro	33°40'N	947.0	1236.0	1630.2	1928.5	2070.2	2194.1	2363.4	2154.0	1717.3	1356.9	1076.4	849.2	1624.5
Fresno	36°44'N	656.7	1012.3	1565.8	2092.6	2483.8	2732.8	2685.1	2421.3	1985.1	1479.2	888.5	574.2	1710.8
Long Beach	33°49'N	927.7	1215.0	1609.9	1937.7	2084.5	2139.9	2299.9	2099.8	1701.0	1326.4	1003.5	846.8	1597.7
Los Angeles	33°56'N	926.1	1214.0	1618.7	1950.9	2059.6	2119.1	2307.5	2079.5	1681.4	1317.0	1003.9	848.5	1593.8
Oakland	37°44'N	707.8	1071.5	1456.3	1922.1	2213.3	2350.0	2322.5	2052.6	1701.1	1212.0	822.1	647.0	1335.2
Point Hugo	34° 7'N	927.2	1218.9	1635.7	1951.0	2038.0	2054.6	2118.3	1934.9	1607.7	1246.1	1004.4	856.2	1552.2
Sacramento	38°31'N	586.9	939.4	1458.4	2002.6	2434.8	2683.8	2688.0	2368.3	1906.7	1317.9	781.9	538.4	1642.9
San Diego	32°44'N	915.7	1266.3	1631.6	1936.7	2002.8	2062.2	2186.5	2057.3	1717.4	1373.9	1062.7	803.8	1598.0
San Francisco	37°37'N	707.6	1009.3	1455.1	1920.0	2225.6	2375.9	2391.6	2116.5	1742.0	1226.1	821.4	642.4	1552.8
Santa Maria	34°54'N	833.8	1140.9	1581.9	1921.0	2140.6	2348.6	2341.3	2105.7	1730.3	1353.4	923.6	803.9	1607.9
Sunnyvale	37°25'N	737.6	1037.5	1485.3	1943.8	2276.8	2452.8	2441.3	2167.1	1759.5	1248.4	843.1	660.3	1587.8

Table 1-1  
Total Horizontal Solar Radiation Intensity (Btu/ft<sup>2</sup>-day)  
from Solar Energy Research Institute

STATE AND STATION	LATITUDE	JAN	FEB	MAR	APR	MAY	JUN	JUL	AUG	SEP	OCT	NOV	DEC	ANNUAL
COLORADO														
Colorado Springs	38°49'N	890.7	1178.2	1550.0	1931.2	2128.7	2368.9	2211.0	2025.4	1759.1	1358.6	949.2	781.9	1594.1
Denver	39°45'N	840.1	1127.0	1530.4	1879.3	2134.9	2350.7	2272.6	2044.1	1726.8	1300.5	883.5	731.8	1568.4
Grand Junction	39° 7'N	791.3	1119.0	1553.5	1986.4	2379.8	2598.5	2465.2	2182.0	1834.4	1345.0	918.1	731.3	1658.7
CONNECTICUT														
Hartford	41°56'N	477.5	714.7	978.5	1315.0	1568.5	1685.0	1649.0	1421.7	1154.5	852.9	497.3	385.1	1058.3
CUBA														
Guantanamo Bay	19°54'N	1403.0	1648.1	1926.3	2170.0	2037.6	1960.8	2082.4	2002.5	1824.0	1584.6	1431.6	1313.0	1777.9
DELAWARE														
Wilmington	39°40'N	571.4	827.0	1149.2	1480.1	1710.2	1882.6	1822.8	1614.6	1317.7	983.9	644.9	488.6	1207.7
DISTRICT OF COLUMBIA														
Washington/Stealing	38°57'N	572.0	815.3	1125.0	1458.9	1718.1	1900.9	1817.5	1617.4	1340.0	1003.8	650.9	481.1	1208.4
FLORIDA														
Apalachicola	29°44'N	852.9	1125.9	1474.0	1878.9	2090.6	1998.3	1813.6	1687.5	1535.4	1371.4	1040.1	817.6	1473.8
Jacksonville	30°30'N	899.9	1164.3	1521.7	1855.7	1956.3	1885.2	1802.0	1694.2	1442.3	1223.1	996.0	817.6	1438.2
Miami	25°48'N	1057.4	1314.0	1603.3	1859.0	1843.6	1707.9	1763.4	1629.8	1456.3	1302.7	1118.6	1019.1	1472.9
Tampa	27°58'N	1010.7	1259.4	1593.7	1908.5	1998.2	1847.4	1752.7	1653.1	1492.0	1346.4	1107.8	935.4	1492.3
GEORGIA														
Atlanta	33°39'N	717.6	948.9	1303.6	1686.2	1853.8	1913.8	1812.2	1708.5	1422.0	1199.9	882.9	674.2	1345.3
Augusta	33°22'N	751.0	1015.2	1308.3	1728.4	1865.1	1903.7	1803.5	1667.1	1409.6	1219.6	916.5	720.9	1361.6
Savannah	32° 8'N	794.7	1043.8	1398.5	1761.4	1852.3	1844.3	1783.5	1620.9	1363.7	1216.7	941.1	753.7	1364.5
HAWAII														
Barbers Point	21°19'N	1207.7	1441.0	1645.1	1833.5	1872.5	2024.5	2018.3	1871.1	1814.7	1554.8	1299.4	1165.7	1662.4
Hilo	19°43'N	1119.8	1246.2	1348.6	1434.8	1553.0	1658.5	1624.5	1592.4	1546.8	1372.1	1104.9	1019.3	1385.1
Honolulu	21°20'N	1179.8	1396.3	1621.7	1795.8	1949.3	2004.4	2002.2	1966.5	1810.1	1540.3	1266.1	1132.5	1638.7
Lihue	21°59'N	1103.0	1299.7	1475.6	1640.7	1824.0	1867.8	1862.5	1818.1	1742.4	1449.4	1154.2	1053.1	1524.2
INDIAN														
Boise	43°34'N	485.3	639.7	1004.1	1826.9	2276.7	2463.2	2612.7	2196.5	1737.2	1137.8	628.3	437.2	1495.5
Lewiston	46°23'N	339.7	609.0	1019.6	1435.0	1842.5	2014.8	2335.8	1931.3	1434.6	859.8	412.8	286.1	1210.1
ILLINOIS														
Chicago	41°47'N	507.0	759.5	1106.9	1459.0	1788.9	2007.0	1943.8	1719.4	1351.9	988.9	565.6	401.5	1215.1
Springfield	39°50'N	584.7	860.9	1143.0	1515.0	1865.5	2096.7	2058.2	1805.8	1453.9	1068.3	676.6	490.1	1301.5

Table 1-1 (continued)  
Total Horizontal Solar Radiation Intensity (Btu/ft<sup>2</sup>-day)  
from Solar Energy Research Institute

STATE AND STATION	LATITUDE	JAN	FEB	MAR	APR	MAY	JUN	JUL	AUG	SEP	OCT	NOV	DEC	ANNUAL
INDIANA														
Evansville	38° 3'N	574.1	823.2	1151.0	1500.8	1782.8	1982.7	1920.3	1735.1	1403.3	1087.0	682.5	498.7	1261.8
Indianapolis	39° 44'N	495.6	746.9	1037.4	1398.4	1688.0	1868.1	1806.3	1643.5	1324.0	977.0	579.1	416.6	1165.0
South Bend	41° 42'N	415.7	659.6	922.5	1387.4	1722.5	1921.9	1852.4	1666.3	1291.3	909.2	491.1	340.3	1138.0
IOWA														
New Moines	41° 42'N	580.7	860.7	1180.5	1556.6	1867.5	2124.8	2096.8	1827.9	1433.9	1067.8	658.3	486.9	1311.8
Mason City	43° 9'N	553.7	834.2	1168.0	1518.6	1895.3	2113.8	2084.2	1832.8	1405.4	1010.5	599.9	443.2	1288.5
KANSAS														
Dodge City	37° 46'N	826.6	1122.0	1476.4	1885.8	2089.1	2358.2	2295.5	2055.3	1686.7	1300.7	899.7	731.9	1560.2
Topeka	39° 4'N	680.9	941.0	1256.9	1641.6	1915.4	2126.4	2127.9	1910.0	1516.4	1146.6	771.6	583.5	1384.8
KENTUCKY														
Lexington	38° 2'N	545.9	779.5	1099.5	1479.2	1747.0	1897.1	1850.4	1685.3	1362.1	1044.2	657.3	485.5	1219.4
Louisville	38° 11'N	545.5	789.3	1102.0	1466.7	1739.8	1903.5	1837.5	1680.2	1361.2	1042.2	652.8	487.9	1215.7
LOUISIANA														
Lake Charles	30° 7'N	728.4	1009.8	1313.4	1570.4	1849.4	1970.3	1787.7	1657.4	1485.2	1381.1	916.6	705.6	1364.6
New Orleans	29° 59'N	834.4	1111.9	1414.8	1780.3	1967.7	2003.8	1813.5	1716.6	1513.6	1335.0	972.6	779.4	1437.0
Shreveport	32° 28'N	762.3	1038.4	1341.5	1612.8	1886.2	2064.8	2013.9	1877.3	1553.9	1303.5	928.6	720.6	1426.1
MAINE														
Caribou	46° 52'N	419.3	724.0	1133.1	1414.2	1577.8	1757.4	1762.4	1500.7	1102.6	688.3	366.4	210.5	1063.3
Pooleand	43° 39'N	450.3	681.9	969.6	1303.9	1567.4	1711.6	1659.1	1460.9	1157.8	822.4	459.3	362.9	1050.6
MARYLAND														
Baltimore	39° 13'N	584.9	840.0	1162.2	1487.9	1713.9	1879.1	1873.2	1599.5	1330.3	997.6	660.3	499.3	1215.0
MASSACHUSETTS														
Boston	42° 22'N	475.5	709.6	1016.4	1325.8	1620.5	1817.1	1749.2	1486.5	1259.9	889.6	502.9	403.0	1104.7
MICHIGAN														
Detroit	42° 25'N	417.4	680.4	1000.2	1399.0	1715.9	1866.1	1835.4	1575.5	1253.2	876.1	477.8	343.5	1120.0
Grand Rapids	42° 53'N	369.6	648.3	1014.4	1411.9	1755.2	1956.5	1914.4	1676.3	1262.1	857.8	475.7	310.7	1135.3
Sault Ste. Marie	46° 28'N	324.8	603.3	1028.6	1383.3	1688.1	1810.8	1835.1	1522.7	1049.3	673.0	331.7	252.9	1041.9
MINNESOTA														
Duluth	46° 50'N	388.6	672.8	1034.5	1372.8	1642.5	1767.2	1854.3	1546.9	1095.0	724.6	380.7	291.7	1064.3
Minneapolis/St. Paul	44° 53'N	464.0	763.9	1103.5	1441.9	1737.3	1927.5	1976.0	1687.0	1254.7	859.6	480.4	353.3	1170.2
MISSISSIPPI														
Jackson	32° 19'N	753.5	1026.4	1349.1	1708.4	1940.8	2024.2	1909.0	1780.5	1509.2	1271.4	901.6	708.8	1408.6

Table 1-1 (continued)  
Total Horizontal Solar Radiation Intensity (Btu/ft<sup>2</sup>-day)  
from Solar Energy Research Institute

STATE AND STADIUM	LATITUDE	JAN	FEB	MAR	APR	MAY	JUN	JUL	AUG	SEP	OCT	NOV	DEC	ANNUAL
MISSOURI														
Columbia	38°49'N	611.5	674.8	1178.8	1525.9	1879.8	2049.5	2116.1	1877.9	1450.4	1109.8	702.7	522.5	1327.6
Kansas City	39°18'N	547.9	594.7	1202.9	1575.0	1872.6	2079.6	2182.1	1862.4	1452.4	1092.3	732.3	561.5	1340.0
St. Louis	38°45'N	627.4	685.6	1204.7	1564.2	1871.3	2092.5	2049.5	1816.5	1459.2	1099.8	718.3	530.6	1326.6
MONTANA														
Billings	45°40'N	468.0	763.2	1489.5	1528.3	1912.8	2173.7	2303.7	2022.4	1470.0	986.8	561.4	421.2	1324.7
Great Falls	47°29'N	470.5	720.2	1170.6	1488.7	1847.6	2101.4	2329.0	1933.0	1378.5	924.6	497.6	336.2	1262.3
Missoula	46°55'N	311.8	374.2	981.5	1382.2	1782.2	1933.0	2327.5	1880.9	1357.8	832.5	410.2	267.2	1169.5
NEBRASKA														
Kearney/Omaha	41°22'N	634.0	692.3	1222.5	1558.4	1872.6	2122.5	2184.5	1858.5	1373.2	1049.8	644.1	511.2	1320.5
Scottsbluff	41°52'N	675.7	950.5	1307.4	1668.0	1933.2	2236.6	2283.7	1949.5	1598.9	1145.0	723.2	575.1	1428.7
NEVADA														
Elko	40°50'N	648.4	1024.4	1463.0	1899.7	2303.3	2533.7	2622.9	2335.9	1892.6	1322.5	812.1	617.0	1625.5
Las Vegas	36° 5'N	978.0	1339.5	1823.5	2111.0	2446.3	2777.8	2588.4	2354.8	2037.3	1539.8	1085.5	880.5	1864.2
Las Vegas	39°30'N	800.4	1149.9	1649.4	2159.3	2523.1	2701.4	2682.3	2405.7	1997.7	1431.0	912.3	705.5	1760.7
NEW HAMPSHIRE														
Concord	43°12'N	459.5	606.1	973.6	1371.1	1582.2	1704.6	1674.6	1455.3	1140.2	817.1	462.7	362.1	1053.0
NEW JERSEY														
Newark	40°42'N	551.7	793.0	1108.7	1448.6	1687.1	1795.3	1759.9	1564.8	1272.9	930.9	598.2	454.4	1165.3
NEW MEXICO														
Albuquerque	35° 3'N	1016.5	1242.0	1767.6	2228.4	2538.1	2678.9	2488.6	2290.1	1971.7	1546.7	1133.7	927.7	1827.5
Flagstaff	36°45'N	944.5	1280.9	1693.4	2132.9	2451.6	2665.5	2478.2	2232.1	1934.3	1476.7	1047.2	837.1	1766.3
Roswell	33°24'N	1046.5	1372.7	1807.4	2217.6	2459.2	2610.3	2400.6	2201.8	1813.0	1527.1	1131.4	951.0	1810.0
NEW YORK														
Albany	42°45'N	656.5	688.4	985.9	1335.2	1549.9	1729.9	1728.9	1498.9	1170.3	817.3	457.1	355.9	1065.8
Buffalo	42°56'N	348.9	546.4	858.5	1314.9	1596.5	1803.7	1775.4	1513.2	1151.8	784.4	403.4	283.3	1034.5
New York City (La Guardia)	40°46'N	576.6	794.5	1113.6	1456.6	1690.4	1801.9	1784.1	1583.2	1280.1	950.4	593.0	454.8	1171.4
NORTH CAROLINA														
Cape Hatteras	35°36'N	685.6	952.2	1326.4	1773.0	1961.8	2035.9	1920.6	1705.4	1470.4	1136.6	872.9	658.7	1375.0
Greensboro	36° 5'N	715.3	970.0	1313.2	1683.2	1868.0	1953.3	1845.6	1696.6	1417.6	1141.6	839.2	658.7	1243.3

Table 1-1 (continued)  
Total Horizontal Solar Radiation Intensity (Btu/ft<sup>2</sup>-day)  
from Solar Energy Research Institute

STATE AND STATION	LATITUDE	JAN	FEB	MAR	APR	MAY	JUN	JUL	AUG	SEP	OCT	NOV	DEC	ANNUAL
<b>NORTH DAKOTA</b>														
Bismarck	46°46'N	466.8	775.7	1168.1	1459.3	1848.1	2059.8	2183.6	1876.7	1354.5	907.8	507.3	372.9	1248.4
Minot	48°16'N	383.7	659.9	1044.3	1460.6	1866.4	1974.8	2097.6	1800.4	1277.0	849.6	438.5	310.0	1178.3
<b>OHIO</b>														
Cincinnati (Covington, KY)	39°4'N	500.5	738.4	1027.3	1398.5	1672.4	1837.1	1770.9	1634.4	1331.6	989.8	588.5	432.5	1158.5
Cleveland	41°24'N	388.4	601.1	922.3	1349.5	1681.1	1843.3	1827.9	1582.6	1239.5	847.0	466.1	317.9	1090.6
<b>OKLAHOMA</b>														
Oklahoma City	35°24'N	800.9	1055.0	1400.1	1725.4	1918.1	2143.9	2128.4	1950.3	1554.2	1232.4	901.0	725.4	1461.3
<b>OREGON</b>														
Medford	42°22'N	404.9	737.4	1132.6	1638.7	2033.7	2277.8	2475.5	2320.6	1589.0	981.9	504.3	336.3	1352.9
Pendleton	45°41'N	348.1	633.6	1043.6	1502.7	1925.5	2144.3	2395.7	1994.0	1502.2	904.1	438.4	293.0	1259.1
Portland	45°36'N	330.0	544.1	895.0	1307.7	1663.2	1772.5	2037.3	1673.7	1236.7	723.6	387.5	259.8	1066.8
<b>PACIFIC ISLANDS</b>														
Koror Island	7°20'N	1397.0	1558.6	1630.9	1691.7	1567.6	1455.5	1442.3	1402.8	1526.8	1506.7	1448.8	1358.8	1503.9
Kwajalein Island	8°44'N	1373.9	1721.9	1769.3	1740.4	1428.8	1610.4	1609.7	1487.1	1635.5	1525.1	1458.4	1450.4	1420.5
Wake Island	19°17'N	1349.3	1572.0	1811.3	1934.3	2054.6	2046.3	1824.5	1871.9	1783.5	1570.7	1436.8	1310.9	1720.1
<b>PENNSYLVANIA</b>														
Philadelphia	39°53'N	555.3	794.5	1108.2	1433.9	1659.4	1811.7	1758.1	1574.5	1281.4	958.5	619.3	470.4	1168.7
Pittsburgh	40°30'N	424.4	625.3	942.6	1316.6	1601.7	1761.6	1689.2	1510.4	1208.9	895.0	504.7	346.8	1068.9
<b>PUERTO RICO</b>														
San Juan	18°26'N	1325.6	1533.9	1787.9	1890.9	1812.9	1817.0	1833.7	1838.2	1674.5	1515.3	1367.7	1235.8	1639.6
<b>RHODE ISLAND</b>														
Providence	41°44'N	506.2	738.5	1031.8	1373.9	1655.1	1775.5	1895.4	1498.6	1208.8	906.7	537.5	418.5	1112.2
<b>SOUTH CAROLINA</b>														
Charleston	32°54'N	344.2	595.3	938.6	1332.3	1860.2	2043.9	1789.9	1585.3	1394.1	1192.7	934.1	720.7	1345.1
Greenville/ Spartanburg	34°54'N	729.6	981.9	1328.5	1697.3	1838.9	1918.2	1830.1	1699.2	1405.4	1180.0	880.3	670.3	1346.6
<b>SOUTH DAKOTA</b>														
Rapid City	44°3'N	542.3	826.5	1228.8	1583.1	1887.0	2131.2	2223.0	1982.7	1517.9	1063.6	646.7	476.4	1341.3
Sioux Falls	43°34'N	532.6	802.1	1152.2	1542.9	1893.7	2099.9	2146.6	1844.5	1409.8	1005.3	607.5	441.3	1290.2

Table 1-1 (continued)  
Total Horizontal Solar Radiation Intensity (Btu/ft<sup>2</sup>-day)  
from Solar Energy Research Institute

STATE AND STATION	LATITUDE	JAN	FEB	MAR	APR	MAY	JUN	JUL	AUG	SEP	OCT	NOV	DEC	ANNUAL
TENNESSEE														
Memphis	35° 3' N	682.7	944.8	1278.3	1638.7	1884.9	2044.6	1972.0	1824.0	1870.9	1204.5	816.7	628.6	1765.9
Memphis	36° 7' N	579.6	823.8	1179.8	1543.6	1824.8	1863.0	1881.1	1736.9	1397.9	1113.8	711.3	520.6	1769.7
TEXAS														
Amarillo	55° 14' N	960.2	1243.5	1630.8	2019.1	2111.7	2393.1	2180.5	2103.1	1760.5	1403.5	1032.9	871.6	1659.2
Austin	50° 18' N	864.5	1174.4	1428.9	1805.1	1832.6	2072.0	2105.5	1931.3	1606.1	1333.3	986.7	825.1	1676.4
Corpus Christi	27° 46' N	898.1	1147.4	1429.9	1642.4	1866.4	2091.8	2186.1	1990.8	1687.0	1416.3	1042.7	844.7	1520.5
Dallas	32° 51' N	821.5	1073.1	1421.8	1626.8	1888.5	2134.9	2122.1	1950.2	1587.1	1176.1	936.4	780.1	1668.1
El Paso	31° 48' N	1175.1	1480.1	1809.3	2161.5	2500.4	2682.5	2450.1	2284.5	1987.1	1639.0	1243.7	1030.7	1899.7
Houston	29° 59' N	772.4	1034.7	1297.4	1522.3	1774.9	1898.1	1888.1	1686.7	1471.0	1275.4	924.0	729.4	1351.1
UTAH														
Cedar City	37° 42' N	882.4	1179.8	1635.6	2092.4	2467.3	2705.8	2505.3	2241.3	1868.4	1459.7	992.4	785.5	1742.8
Salt Lake City	40° 46' N	639.1	988.7	1458.1	1894.3	2362.4	2560.9	2560.1	2351.6	1893.3	1293.3	787.9	549.8	1603.1
VERMONT														
Rutland	44° 28' N	385.3	604.6	940.2	1296.2	1574.1	1728.9	1721.1	1475.0	1122.2	740.5	514.4	283.2	1020.7
VIRGINIA														
Worfolk	36° 54' N	678.3	931.9	1280.9	1678.7	1887.5	2000.3	1853.2	1680.2	1395.6	1043.0	811.3	623.8	1325.2
Richmond	37° 30' N	631.9	877.1	1210.4	1566.0	1762.0	1872.4	1774.4	1600.6	1347.9	1032.7	733.0	566.7	1248.0
Roanoke	37° 39' N	660.5	899.4	1216.1	1581.5	1763.9	1881.9	1796.2	1620.2	1358.2	1080.2	764.7	590.8	1269.3
WASHINGTON														
Seattle/Tacoma	47° 27' N	263.7	495.0	849.4	1293.5	1713.9	1881.8	2248.2	1616.3	1147.7	856.2	597.2	311.1	1052.7
Spokane	47° 38' N	315.0	605.9	1040.6	1494.9	1918.0	2082.8	2337.4	1942.0	1435.3	840.9	597.7	255.2	1223.8
WEST VIRGINIA														
Charleston	38° 22' N	498.4	704.5	1009.5	1355.7	1659.4	1775.9	1682.5	1514.3	1272.0	972.3	613.1	440.1	1123.3
WISCONSIN														
Green Bay	44° 29' N	451.2	724.9	1104.2	1438.6	1719.3	1907.8	1888.5	1621.8	1218.0	820.6	465.1	349.7	1142.5
Madison	43° 8' N	535.2	804.0	1136.0	1508.4	1743.2	1847.9	1934.4	1704.1	1299.4	910.9	504.2	388.9	1140.9
Milwaukee	42° 57' N	479.4	736.5	1088.8	1442.7	1768.4	1977.1	1841.8	1719.0	1310.3	907.9	524.6	378.4	1131.2
WYOMING														
Cheyenne	41° 9' N	765.8	1047.8	1433.1	1770.5	1994.4	2258.0	2229.0	1965.5	1667.4	1241.8	822.8	671.0	1490.7
Rocky Mountain	41° 36' N	355.0	1049.4	1530.1	1943.9	2344.3	2574.4	2547.2	2140.2	1812.5	1295.9	824.3	630.4	1623.0

Table 1-1 (continued)  
 Total Horizontal Solar Radiation Intensity (Btu/ft<sup>2</sup>-day)  
 from Solar Energy Research Institute

The amount of solar energy collected by a solar collector depends on its efficiency, which is determined by how it is constructed, its configuration, and the choice of materials used. Standards are available as given in herein which can test the instantaneous efficiency of a solar collector for a specified set of operating conditions. Other parameters, not related to the physical characteristics of a solar collector, can affect performance. The atmosphere reduces the radiation received on the earth's surface and is also responsible for the scattering of light which results in diffuse, as distinct from direct, solar radiation. The diffuse component may represent as much as 25%-30% of the total solar radiation depending on the weather conditions. Cloudy days are virtually 100% diffuse solar energy. Solar flat plate collectors absorb heat from the diffuse component as well as the direct. Thus, some heat is available on partly cloudy days. The reflectance of the ground (snow, sand, water, etc.) or nearby objects may also influence the amount of solar energy reaching a collector. Therefore, the amount of solar energy received at any location depends on the hour of the day, the day of the solar year, and the meteorological conditions. This amount can vary from about 50 Btu/ft<sup>2</sup>-hr on a foggy winter day to as much as 300-375 Btu/ft<sup>2</sup>-hr on a typical sunny summer day.

**1.3.3 SOLAR COLLECTOR ORIENTATION.** Even though solar collectors can collect heat from the diffuse component of solar radiation, solar systems are designed to use the direct component. Direct radiation is in the form of parallel rays coming straight from the sun. To best capture this energy the solar collector should be tilted as shown in Figure 1-2 so that it is more nearly perpendicular to the solar rays. The "optimum" tilt angle varies even as the sun changes its position throughout the day and year. However, since the solar system cannot be continuously moved, some general rules can be stated:

**1.3.3.1** For all year domestic hot water (DHW) heating use a tilt angle equal to the latitude.

**1.3.3.2** For all year DHW heating and winter space heating, use a tilt angle equal to the latitude plus 10-15 degrees.

1.3.3.3 For all year DHW heating, winter space heating, and summer cooling use same as above.

1.3.3.4 For winter only space heating use a tilt angle equal to the latitude plus 10-15 degrees.

1.3.3.5 For summer space cooling use a tilt angle equal to the latitude minus 10-15 degrees.

1.3.3.6 For summer only space cooling and all year DHW heating use the same as above.

In addition to choosing the best collector tilt angle, consideration must be given to the orientation of a collector (i.e., the direction the collector faces). Normally true south is the best and most frequent choice. However, slightly west of south (10 degrees) may be preferable in some locations if an early morning haze or fog is a regular occurrence.

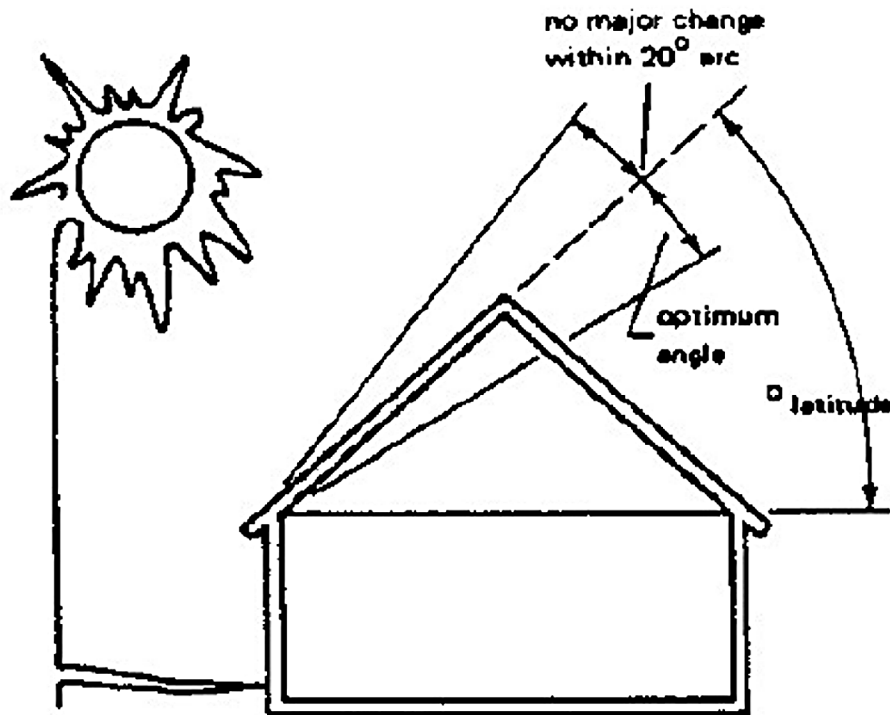

Figure 1-3

Collector tilt for domestic hot water(usually = latitude, but 10 deg variations either side of optimum are acceptable



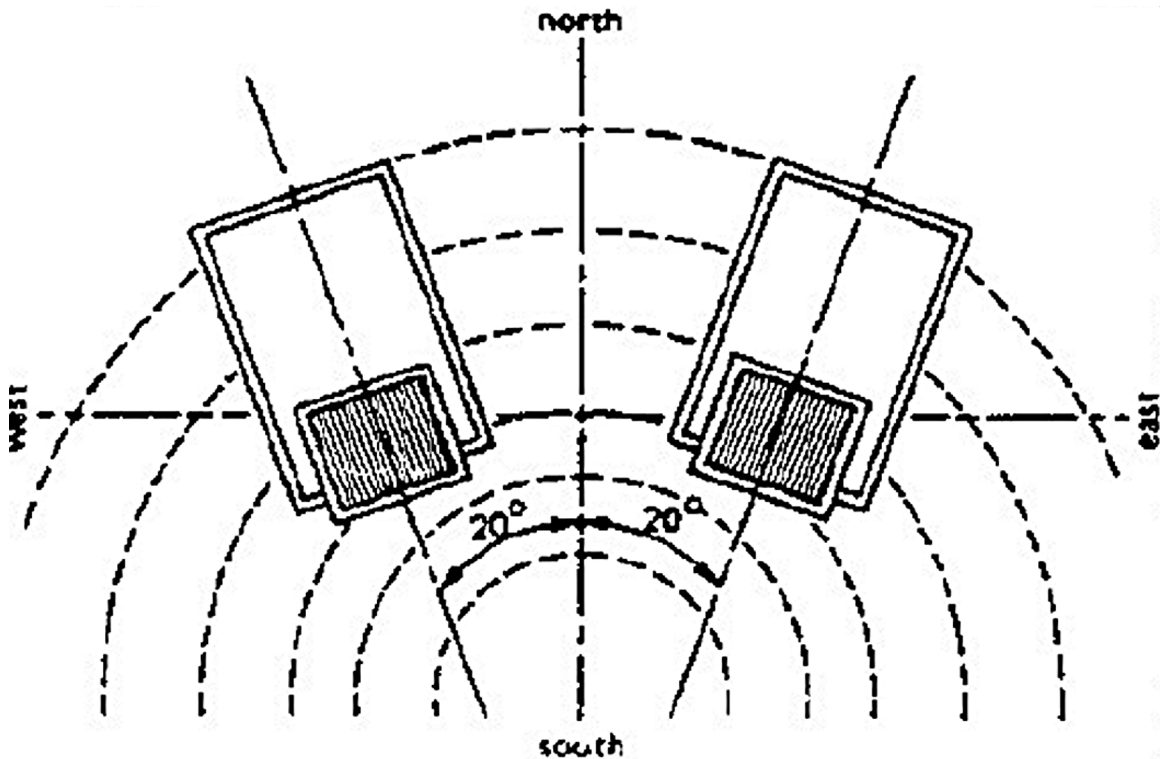

Figure 1-4

Collector orientation (optimum = true south, but 20 deg variations to either side are acceptable; local climate and collector type may influence orientation)

Some deviations from these tilt and orientation angles are allowable without significantly affecting performance. As shown in Figures 1-3 and 1-4, the tilt angle may vary +/- 10 degrees and the orientation angle up to 20 degrees either side of true south (National Solar Heating and Cooling Info Center, 1979). For these deviations the solar collectors would still collect 95%- 100% of their rated capacity in most locations of the U.S. Additional deviations would require more collector area to capture the same amount of energy. As a very approximate rule of thumb, for each deviation of 10 degrees beyond that shown in Figures 1-3 and 1-4 add 10% more collector area. If you must choose between an east roof and a west roof, use the west roof in the western coastal area. Other areas will require local weather considerations. As important as collector location, is keeping the collectors out of the shade, especially between 9 a.m. and 3 p.m., when most of the useful energy collection occurs. The designer should try to

anticipate any future structures or vegetation (trees) that could block future solar access. In summary, although many buildings will not have a "perfect" solar orientation, there can still be many places with good solar energy potential.

**1.3.4 ADVANTAGES AND DISADVANTAGES.** Solar energy is inherently nonpolluting, provides substantial freedom from the effects of fuel price increases, and saves valuable fossil fuels. Disadvantages are that collectors perform poorly in cold cloudy weather, when most needed; and room heat exchangers and industrial unit heaters must be larger than in conventional systems due to the relatively low temperature of heating fluid. The disadvantages may be circumvented by good design; where fuel costs are high enough (as discussed in the examples, Section 4), a solar system will prove cost effective. Solar systems designed for combined heating and cooling will utilize the collector all year and thus are potentially more cost effective.

**2. FLAT PLATE SOLAR COLLECTORS.** This section will cover in detail the typical components of a flat plate solar collector as shown previously in Figure 1-2.

**2.1 COLLECTORS.** The collector is the most important and one of the most expensive parts of a solar heating system. It must be long-lived and well insulated, yet its cost must be minimized. Collectors of primary interest for space and water heating are of two basic types: liquid and air. Liquids may be water, an antifreeze mixture, or various hydrocarbon and silicone heat transfer oils. Air-type collectors use air as the collector fluid. The absorber plate is that part of the collector which absorbs the solar energy and converts it to thermal energy. A portion of the thermal energy is carried to the building or thermal storage unit by the fluid which circulates through passages in the absorber plate. The absorber plates can be made of metal, plastic, or rubber compounds. The metals commonly used in order of decreasing thermal conductivity are copper, aluminum, and steel. Plastics (polyolefins) and rubbers (ethylene propylene compounds) are relatively inexpensive, but due to their low thermal conductivity and their temperature limitations, they are suitable only for low temperature applications, such as heating swimming pool water or for use with water source heat pumps. Typical

cross sections of solar collector types are shown in Figure 2-1. Other major components of a solar collector include:

- Absorber plate coating - To enhance the heat transfer and protect the absorber plate.
- One or more transparent covers - To reduce thermal losses by radiation (using the "greenhouse effect") and by convection (wind, etc.). Spacings are nominally 1/2 inch or more.
- Insulation - One to three inches are used to reduce heat loss through the side and back of the absorber plate.
- Collector box or housing - To provide a rigid mounting to hold the components. Must be weatherproofed.
- Gaskets and seals - To insure a weathertight seal between components while allowing thermal expansion of the components. Normally these seals remain ductile to accomplish their purpose.

Flat-plate collectors are most suitable for low temperature applications such as domestic hot water and space heating. They collect both direct and diffuse radiation. It is not required that they track the sun, thus initial cost and maintenance are minimized. A properly designed flat-plate collector has a life expectancy of 10 to 25 years, or sometimes longer. All copper and glass systems currently exhibit the longest lives. Using softened water will help. Tubes should be 1/2 inch in diameter or greater for low pressure drop and longer life. The better the attachment of tube-to-plate (such as by soldering), the better the heat transfer, but the greater the manufacturing cost. Advances in collector cost reduction will probably be made in the direction of cheaper manufacturing processes. Some collectors not made from tube and sheet may not tolerate DHW line pressures. Specifications for pressurized collector circuits should require collectors which will take proof test pressure equal to 150% of expected circuit pressure. In hot climates, it is important to reduce roof heat load due to collector heat gain in summer; this can be accomplished by venting the space between collector plate and glazes with dampers or by covering the collectors. A normal amount of dirt and dust

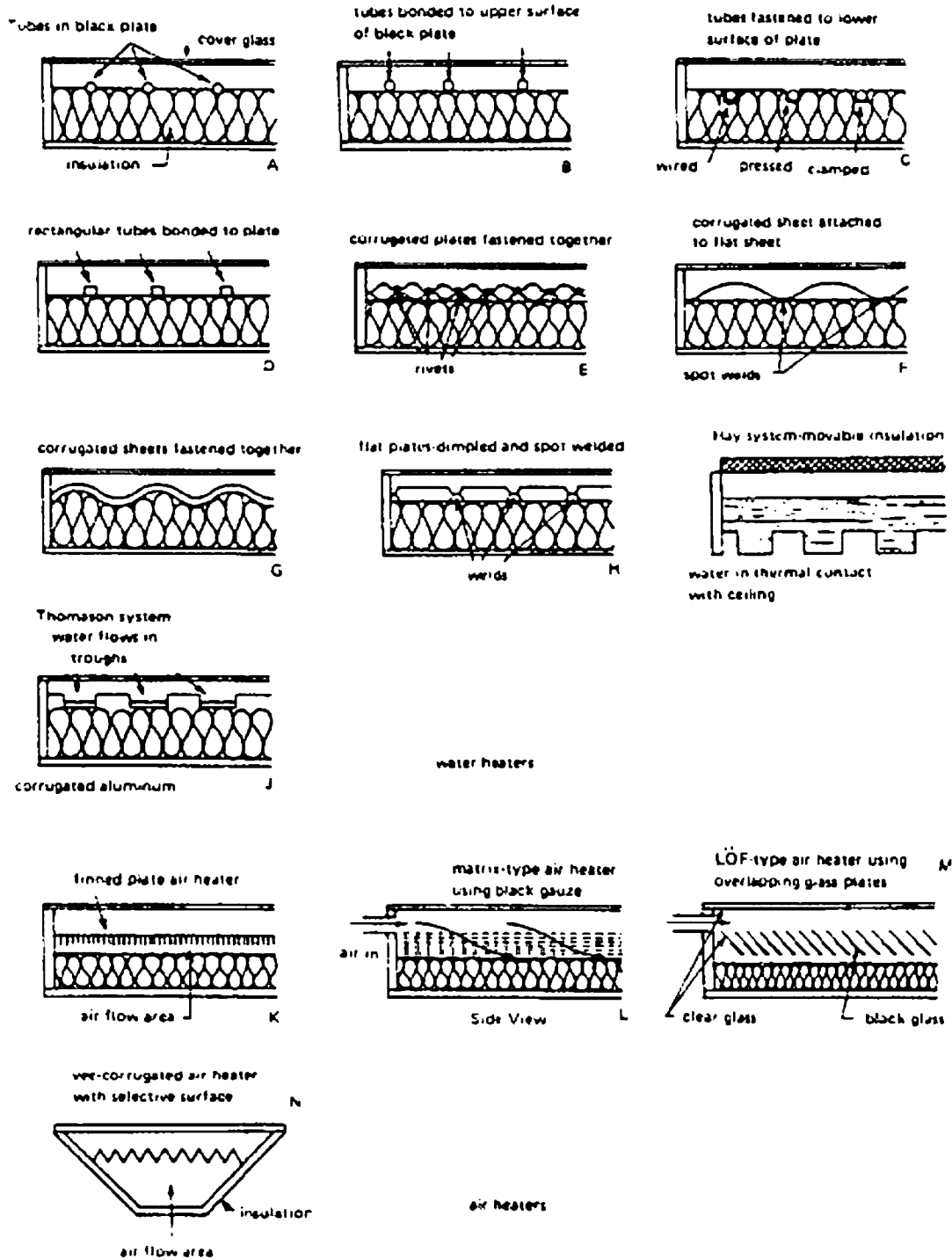

Figure 2-1  
Types of Solar Heat Collectors

on the glass cover will reduce heat collected by about 5%. Normal rainfall is usually sufficient to relieve this problem. Except for warm climates with high insolation ( $I > 1400 \text{ Btu/ft}^2\text{-day}$ ), two cover glasses may be optimum. In warm climates, one glass is optimum. Many plastics have an undesirable transparency to infrared radiation, to which glass is nearly opaque, so the desired "greenhouse effect" is not so pronounced with plastic materials as with glass. However, losses by radiation from the collector are small compared with convective losses due to wind; thus plastics can be employed to reduce breakage and cost, but with some loss in collector performance. Plastics with maximum opaqueness to infrared and maximum transparency to ultraviolet (UV) and visible radiation and with high resistance to UV degradation should be specified. The following sections give more detailed information on collector designs and components.

**2.1.1 LIQUID AND AIR-TYPE COLLECTORS.** Liquid and air type collectors each have some advantages which are summarized in Table 2-1. Liquid types are more suited to DHW, the collector area is usually smaller, and more information is available about liquid systems. Collectors for heating air do not require protection from freezing and have minimal corrosion problems, leaks do not cause serious damage, they may cost less per unit area, and are better suited to direct space heating for residences where duct-work is already present. However, since leaks in air systems are less easily detected, they can degrade system performance if not corrected. Wherever this manual discusses liquid collectors, air collectors are included, and cost analyses apply equally to both. The design procedure for air collectors differs, however. Heat transfer oils used in liquid systems offer freeze protection and some corrosion protection, but they also require heat exchangers for heating domestic hot water, as do antifreeze-water mixtures.

**2.1.2 SELECTIVE SURFACES.** Some collectors are manufactured with a black coating which absorbs the high frequency incoming solar radiation very well and which emits low frequency infrared radiation poorly. This is a highly desirable combination of properties for a collector. The absorptance should be 0.9 or higher and emittance may be 0.1 or lower. Such coatings are approximately equal in effect to one cover glass.

Air	
Advantages	Disadvantages
<p>Moderate cost</p> <p>No freezing or corrosion problems.</p> <p>Minor leaks cause little or no damage.</p> <p>As air is used directly to heat the house, no temperature losses due to heat exchangers (devices which transfer heat from one fluid to another), when the system is used for space heat.</p> <p>No boiling or pressure problems.</p>	<p>Can only be used to heat homes; cannot presently be economically adapted to cooling.</p> <p>Large air ducts needed. Fan power is required.</p> <p>Large storage space needed for rocks.</p> <p>Heat exchangers needed if system is to be used to heat water.</p> <p>Undetected leaks can degrade system performance.</p> <p>Possible fungus or algae growths in rock beds. Long term effects unknown.</p> <p>Washing rock can be difficult.</p>
Water or Liquid	
Advantages	Disadvantages
<p>Holds and transfers heat well.</p> <p>Water can be used as storage.</p> <p>Can be used to both heat and cool homes.</p> <p>Compact storage and small conduits.</p> <p>Compatible with hydronic heating systems.</p> <p>Pumps are quieter and more effective than fans.</p>	<p>Leaking, freezing, and corrosion can be problems.</p> <p>Corrosion inhibitors needed with water when using steel or aluminum. There are liquids which are noncorrosive and nonelectrolytic; however, they are toxic and some of them are flammable.</p> <p>A separate collector loop using a nonfreezing fluid and heat exchanger. Or, alternatively, a water draining or inhibited water system, are required to prevent freezing. In warm regions, where freezing is infrequent, electric warmers or recirculation can be used.</p> <p>May require excess heat protection.</p>

Table 2-1

Advantages and Disadvantages of Air and Liquid Heating Systems

Thus, a selective coating plus one cover glass may be expected to be about equal in efficiency to a collector with two cover glasses and a flat black painted surface.

Electroplated black nickel, black chrome, copper oxide or anodized aluminum are common types of selective coatings. Cost of selective surface coatings may be greater than an extra sheet of glass, but much research is being done to produce low cost, easily applied coatings. The stability of black nickel, chrome and aluminum in the presence of moisture has not yet been proven. Long-term stability in the presence of moisture or other expected environmental factors (salt air, etc.) must be included in specifications for selective surfaces. Table 2-2 is a summary of absorber coatings both selective and nonselective.

**2.1.3 COLLECTOR COVERS (GLAZES).** The transparent covers serve to admit solar radiation to the absorber while reducing convection and radiation heat losses from the collector. The covers also protect the absorber from dirt, rain, and other environmental contaminants. The material used for covers include glass and/or plastic sheets. Glass is most commonly used because of its superior optical properties and durability. Standard plate glass reflects about 8% and absorbs about 6% of normal incident solar radiation, resulting in a transmissivity of about 86%. Yet it is essentially opaque to long-wave thermal radiation from the absorber. Transmission of solar radiation into the collector can be increased by minimizing the reflectance and the absorptance of the glass covers. Absorptance of solar radiation by the collector can be increased with the use of thinner tempered glass and by using glass that has a low iron content. Although glass is subject to impact damage and is more expensive than plastic, it does not degrade in sunlight or at high collector temperatures, and is generally considered to be more durable than plastic. Impact damage may be reduced with the use of tempered glass and small collector widths. Also 1/2-inch wire mesh may be hung over glass covers for protection, but the effective absorber area will be reduced by approximately 15%. In general, screens are not recommended. Most plastic covers transmit the solar spectrum as well or better than glass glazing. Unfortunately, they transmit infrared

Property/ Material	Absorptance, [α] [alpha]	Emittance, [ε] [epsilon]	[α] [epsilon]	Breakdown Temperature deg. F (deg. C)	Comments
Black Chrome	0.87-0.93	0.1	9		
Alkyd Enamel	0.9	0.9	1		Durability limited at high temperatures.
Black Acrylic Paint	0.92-0.96	0.86-0.93	1		
Black Inorganic Paint	0.89-0.97	0.84-0.90	1		
Black Silicone Paint	0.86-0.94	0.83-0.89	1		Silicone binder.
PbO/Silicone Paint	0.94	0.4	2.5	662 (350)	Has a high emittance for thickness > 10[μm].
Flat Black Paint	0.95-0.98	0.89-0.97	1		
Ceramic Enamel	0.9	0.5	1.8		Stable at high temperatures.
Black Zinc	0.9	0.1	9		
Copper Oxide Over Aluminum	0.93	0.11	8.5	392 (200)	
Black Copper Over Copper	0.85-0.90	0.08-0.12	7-11	842 (450)	Patinaes with moisture.
Black Chrome Over Nickel	0.92-0.94	0.07-0.12	8-13	842 (450)	Stable at high temperature.
Black Nickel Over Nickel	0.93	0.06	15	842 (450)	May be influenced by moisture at elevated temperatures.
Ni-Sn-O Over Nickel	0.96	0.07	14	536 (260)	
Black Iron	0.90	0.10	9		
Sunsponge Foil	0.93-0.95	0.08-0.12	8-11	500 (260)	TradeName Aluminum Foil of Berry Solar Products

Table 2-2  
Characteristics of Absorber Coatings  
(selective coatings alpha/epsilon > 2; non-selective coatings alpha/epsilon – 1)



Thermalox 250 Paint	0.96	0.52	1.9	1000 (535)	Dampney Company
Maxorb Solar Foil	0.96	0.10	9.6	392 (200)	Nickel Foil Ergenics Co.
Solkote Hi/Sorb	0.95	0.37	2.6	1000 (535)	Spray Paint of Solar Energy Corp.
Scotchbrand SC 7001X Foil	0.96	0.07	13	400 (204)	3M Black Nickel Foil

[a] Dependent on thickness and vehicle to binder ratio.

Table 2-2 (continued)  
 Characteristics of Absorber Coatings  
 (selective coatings alpha/epsilon > 2; non-selective coatings alpha/epsilon – 1)

Glazing Type	Solar (Shortwave) Transmittance (%)	Infrared (Longwave) Transmittance (%)	Index of Refraction	Weatherability[a] and Durability
White Crystal glass	91.5	2	1.50	Excellent
Low-Iron Tempered Glass	88-89	2	1.51	Excellent
Low-Iron Sheet Glass	88-89	2	1.51	Excellent
Tempered Float Glass	84.3	2	1.52	Excellent
Fiberglass Rein- forced Plastic (FRP)[b]	85-89	5-20	1.54	Good
Sheet Acrylic	88-92	10-25	1.49	Average to Good
Sheet Polycarbonate	82-90	10-20	1.59	Fair to Good
FEP Teflon	92-96	25-26	1.34	Good
Polyester Film	80-87	20-25	1.64-1.67	Fair to Good
Polyethylene Film	88	80	1.64	Poor

[a] Durability and weatherability of many plastics is still to be determined by field use. Some testing by NBS (Technical Note 1132) suggests that over a 24 month period glass covers will lose about 0-2% of their transmittance and plastic covers about 5-13%. Accumulated dirt accounted for another 4% average loss over the same period on both types (however, this dirt could be washed off). Of the plastic covers, FEP Teflon seemed to have the least weathering (0.5 to 4.3% loss) and the most dirt accumulation (5.4-7.7% loss).

[b] Common trade names - Kalwall Durlight and Tedlar-Glad filon.

Table 2-3  
 A Comparison of Various Materials Used for Collector Covers.

radiation well also, increasing radiation losses from the collector. Table 2-3 compares the different characteristics of glass and plastic covers. Although resistant to impact damage, plastics generally degrade in sunlight and are limited as to the temperatures they can sustain without undergoing serious deformation. Often they do not lie flat, resulting in a wavy appearance. In general, acrylic is the most UV resistant and FRP Plastics offer good impact and high temperature properties. Teflon FEP film has good transmittance and high temperature properties, but is limited in strength. Some collectors using plastic covers are designed to have stagnation temperatures no higher than 200 deg. - 275 deg. F. However, plastic covers have been developed to withstand 400 deg. F. The manufacturer should be consulted. Each additional cover, whether it be glass or plastic, reduces convection heat losses but results in added expense and less solar radiation transmitted to the absorber. Most commercially available collectors come with one or two covers. The decision to use one or two covers depends on the type of absorber coating, the required collection temperatures, average ambient air temperature, the local wind conditions, and of course, the cost of the covers. The use of a selective surface is about equal to using one additional cover. Thus for most cases, only one glass cover is needed if the absorber has a selective coating. In fact, one study indicated that winter performance was actually reduced by the use of two glass covers with a selective surface compared to one cover with the selective surface. Two covers are generally recommended for use in Northern climates where winter ambient air temperatures are low. For flat-plate collectors used mostly for winter heating, one rule of thumb is to use one glass cover where average winter air is greater than, 45 deg. F, and two glass covers in colder climates. Table 2-4 gives some approximations in the selection of collector covers.

**2.1.4 COLLECTOR INSULATION.** Insulation behind and to the side of the absorber serves to reduce conduction losses. Usually, this insulation consists of 1-6 inches of high-temperature fiberglass batting or semi-rigid board or even mineral wool. Styrofoam and urethane foams are usually not used because they may deform at high temperatures or give off gases (which may be toxic). The insulation should be

Collection Temperature Above Ambient Temperature ( $t_{rc} - t_{ra}$ )	Typical Applications	Optimum Number of Cover Plates	
		Black-Painted Absorber [epsilon] = 0.9 or 0.95	Selective Absorber [epsilon] = 0.2 or less
-5 deg. C to +5 deg. C (-10 deg. F to +10 deg. F)	Heat source for heat pump Heating of swimming pools in summer Air heating for drying	none	none
5 deg. C to 35 deg. C (10 deg. F to 60 deg. F)	Domestic water heating Heating of swimming pools in winter Air heating for drying Solar distillation Space heating in non-freezing climates	1	1
35 deg. C to 55 deg. C (60 deg. F to 100 deg. F)	Winter water heating Winter space heating	2	1
55 deg. C to 80 deg. C (100 deg. F to 150 deg. F)	Summer air conditioning Steam production in summer Refrigeration Cooking by boiling	3	2

Table 2-4

Guide to Selection of Number of Transparent Cover Plates.

separated from the absorber plate by 1/2 to 3/4 inch and have a reflective foil facing the absorber plate. If fiberglass insulation is used, it should not be typical construction grade which contains phenolic binders that may "outgas" at the stagnation temperature of the collector. In all cases, specifications should call for insulations that are not flammable, have a low thermal expansion coefficient, do not melt or outgas at collector stagnation

temperatures (300 deg. – 400 deg. F), and (whenever possible) contain reflective foil to reflect thermal radiation back to the absorber.

**2.1.5 COLLECTOR HOUSINGS.** The housing or collector box serves to:

- Support the collector components.
- Protect the absorber and insulation from the environment.
- Reduce convection and conduction losses from the absorber.

Many housing designs are available on the market. They are constructed of metals, wood, plastics, concrete, and other materials. The most commonly used materials are aluminum, galvanized sheet metal, fiberglass laminates, high temperature thermoplastics, and wood. It is recommended that wood be avoided for use as a structural member, spacer, or anchor for panels due to its susceptibility to deterioration and flammability. All structural materials are suitable if properly used. However, most commercially available housings consist of a galvanized sheet metal box with an anodized aluminum frame which fits on top of the box. Some housings are designed to be integrated directly into the roof or wall structure, thus reducing construction costs.

Since field labor is expensive, the collector housing should be designed such that the collector units can be quickly secured in place and connected to the external piping. Provisions should also be made for easy replacement of broken glass covers. The absorber plate should be mounted so as to be thermally isolated as much as possible from the housing.

**2.1.6 COLLECTOR GASKETS AND SEALANTS.** Gaskets and sealants must be carefully selected if a collector is to have a long life. Generally, the housing and the glazing have different rates of thermal expansion. Gaskets and sealants form the flexible interface between the two components and seal out moisture and other contaminants; if they fail, moisture will fog the glazing and may possibly damage the absorber coating and the insulation. These problems can drastically reduce the thermal performance of the collector. Two suitable sealing methods are shown in Figures 2-2 and 2-3. The gaskets provide flexible support and the primary weather sealant insures

Company	Useful Temperature Range (°C)	Specific Heat (KJ/KG/°C)	Viscosity	Specific Gravity	Toxicity	Flash Point	Other Features/ Specifications
BMAY OIL CO., INC. Los Angeles, CA							
Synthetic hydrocarbon Synco 898	-40 to 300	0.33 at 60°	0.3 cs at 100° 2.9 cs at 210°	0.8 at 60°	Low	325° (Med.)	Formulated for aluminum systems. Noncorrosive & nonpoisonous.
BOV CHEMICAL, U.S.A. Midland, MI							
Overheat inhibited propylene glycol	-28 to 300	0.35 at 40° (50% water solution)	70 cps at 0° (50% water solution)	1.05	Low	None	Not compatible with aluminum or steel.
Southco 28-1. Inhibited ethylene glycol	-40 to 300	0.87 at 200° (50% 28-1 by weight)	0.4 cps at 200° (50% 28-1 by weight)	1.13	High	250° (Low)	Provides corrosion protection for all common metals.
Southco J. alkylated aromatic fluid	-100 to 575 with 10-20 psig	0.5 at 200°	0.7 cps at 100° 0.25 cps at 200°	0.87	Low	345° (Low)	Resists both thermal degradation and oxidation.
Southco HP	15 to 350	0.640	-	-	-	420° (Med.)	-
BOV CORP/BO CORP. Midland, MI							
Bov Corning Q2-1132 silicone heat transfer liquid	-50 to 450	0.37 at 104° 0.42 at 392°	20 cs at 77° 7 cs at 210°	0.946 at 77°	Low	450° (High)	Water clear liquid. Thermally noncorrosive. Negligible thermal degradation at 400°.
Syltherm 446. silicone heat transfer fluid	-25 to 300	0.37 at 104° 0.42 at 392°	20 cs at 77°	0.37 at 104° 0.42 at 392°	None to Low	450° (High)	Similar to Q2 1132.
DMW CHEMICAL CORP. Boston, NJ							
Dynal heat transfer fluid	-28.5 to 270	0.87 (avg.)	8.8 cps at 77°	1.136 (avg.)	None	None	Inhibits corrosion. Will not deteriorate asphalt.
EXXON							
Exxon SY A3 petroleum base with paraffinic stock (hydrocarbon)	15 to 600	0.66 at 127°	20.9 cs at 100°	0.85	None	470°	-
HAZK ENTERPRISES, INC. Woodbridge, CT							
H-300: synthetic hydrocarbon heat transfer fluid (blue)	-40 to 460	0.50 at 100°	220 cps at 32° 22 cps at 100° 4.3 cps at 200°	0.845	None	340° (Med.)	Noncorrosive. Will not attack metals, PVC, or elastomers except butyl rubber. High thermal conductivity.
H-20. synthetic hydrocarbon heat transfer fluid (green)	15 to 460	0.57 at 100°	210 cps at 32° 24 cps at 100° 8.2 cps at 200°	0.815	None	310° (Med.)	Noncorrosive. Will not attack metals, PVC, or elastomers except butyl rubber. High thermal conductivity.

Table 2-5  
Heat Transfer Fluids

Company	Useful Temperature Range (°F)	Specific Heat (Btu/lb/°F)	Viscosity	Specific Gravity	Toxicity	Flash Point	Other Features/Remarks
MOBIL Mobiltherm 400 refined oil (hydrocarbon)	5 to 600	0.42 at 50°	55 cc at 100°	0.87	None	350° (Med.)	Highly aromatic
MONSANTO INDUSTRIAL CHEMICALS COMPANY St. Louis, MO Therminol 44, 55, 60 64 and 88 synthetic based fluids	-60 to 650	0.32 to 0.72 over temp. range	4,000 to 0.23 cc over temp. range	0.79 to 1.04 over range	Low	310° to 650° (Med.)	Wide range of applications not used with plastic elastomers.
NUCLEAR TECHNOLOGY CORP. Ames, CT Matah 800 Series: *Ethylene glycol  *Propylene glycol and water-based compounds	-30 to 230  32 to 212	0.86 to 0.93 at 60°  0.80 to 0.87 at 60°	3.4 cps at 100° 0.6 cps at 200°  0.7 cps at 100° 0.3 cps at 200°	1.03 to 1.07  1.03 to 1.04	High  Low	None  None	Matah 800 Series are designed for use in aluminum pump collector panels where corrosion and stalling protection is required.
PERDUE TECHNOLOGY CORP. New Britain, CT Sun-Temp nonaqueous heat transfer fluid	-40 to 500	0.56 at 32°	89 cps at 35° 2.1 cps at 232°	0.6 at 32°	None	380° (Med.)	Noncorrosive to aluminum, copper or steel.
SHELL Hydrocarbon oil Thermal C	20 to 550	0.46 at 100°	62.9 cc at 100°	0.86 at 100°	None	455° (High)	-
SUNMOBIL Sunsol 60 Propylene glycol	-55 to 230	0.82 at 37°	4 cps at 100°	1.06 at 35°	Low	None	Maintain pH between 8.3 and 8.0.
UNION CARBIDE CORP. Tarrytown, NY UCAR 17 Inhibited ethylene glycol  UCOW 70 Polyglycol	-33 to 300  -30 to 230	0.79 at 190°	60 cps at -10° 1.5 cps at 190°  65.6 cc at 100°	1.1 at 90°	High  Low	Low  535° (High)	Formulated for use in multi-metal systems. All values at 70% volume in water.  -
UNITROYAL CHEMICAL DIVISION OF UNITROYAL, INC. Branford, CT Synthetic polyalphaolefin	-40 to 600	0.50	10 cc at 200°	0.81	None	400° (Med.)	Relatively non-toxic and non-corrosive. Usually low pour point and volatility.

Table 2-5 (continued)  
Heat Transfer Fluids

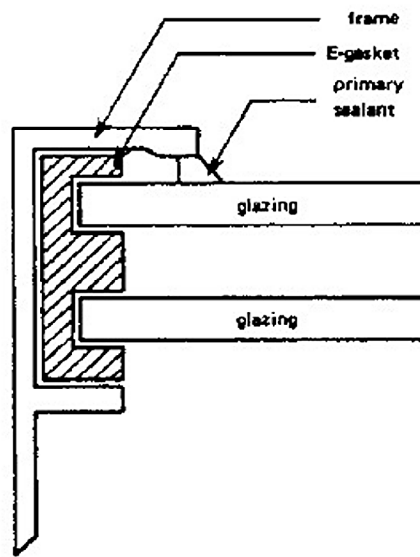

Figure 2-2  
Single gasket seal for double glazing

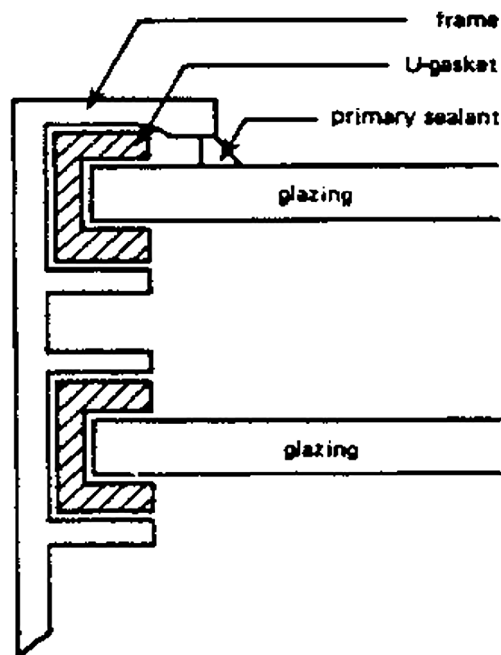

Figure 2-3  
Typical sealing method for single or double glazing

against moisture leakage. Desiccants are sometimes placed between the two glazings to absorb any moisture that may remain after cover installation. When selecting collector gaskets and sealants, certain material requirements must be kept in mind. The gaskets and seals must:

- Withstand significant expansion and contraction without destruction.
- Adhere effectively to all surfaces.
- Resist ultraviolet degradation.
- Resist outdoor weathering.
- Not harden or become brittle.
- Withstand temperature cycling from -30 deg. to 400 deg. F.
- Not outgas at high temperatures.

Both EPDM and silicone rubbers have been found adequate for use as gasket materials. Silicone sealants have exceptional weathering resistance and have received widespread use for many years.

**2.1.7 COLLECTOR FLUIDS - CORROSION AND FREEZE PROTECTION.** The choice of which collector fluid to use is important because this is the life-blood of the system. The cheapest, most readily obtainable, and thermally efficient fluid to use is ordinary water. However, water suffers from two serious drawbacks - it freezes and it can cause corrosion. Therefore, the choice of collector fluid is closely linked to the type of solar system, the choice of components, future maintenance, and several other factors which will be discussed in this section. Implicit in this discussion is the use of a fluid other than air as the collector fluid. As explained in Table 2-1 an air solar system does not suffer from corrosion or freezing effects, but its low density and heat capacity require the use of fans and large ducts, large storage volumes, and is generally not suitable for domestic water heating. The remainder of this section applies to liquid solar heating systems. Generally the standards state that the heat transfer fluid must be nonionic, high dielectric, nonreactive, noncorrosive, nonflammable and stable with temperature and time. If the fluid is toxic it may be used only in systems specially designed for it as will be explained later. The National Bureau of Standards (1980), Ref - DOE Solar Heating Materials Handbook, has proposed the following criteria to reduce the risk of



fire in the use of solar heat transfer fluids: The flash point of the liquid heat transfer fluid shall equal or exceed the highest temperature determined from (a), (b) and (c) below:

- (a) A temperature of 50 deg. above the design maximum flow temperature of the fluid in the solar system; or
- (b) (1) A temperature 200 deg. F below the design maximum no-flow temperature of the fluid attained in the collector provided the collector manifold assembly is located outside of the building and exposed to the weather and provided that relief valves located adjacent to the collector or collector manifold do not discharge directly or indirectly into the building and such discharge is directed away from flames and ignition sources; or,  
(2) The design maximum no-flow temperature of the fluid in all other manifold and relief valve configurations;
- (c) 100 deg. F

If there is no danger of freezing and the collector loop consists of all copper flow passages, then ordinary water would be the choice for collector fluid. If freezing conditions are encountered, there are a number of designs that should be considered before it is decided to use a heat transfer oil or antifreeze mixture. These freeze protection schemes are summarized here using Figure 2-4 as the basic open loop type collector circuit.

**2.1.7.1 DRAIN DOWN OR DRAIN BACK METHOD** - The water in the collector is drained out of the system, or into a tank near the collector, or into the main storage tank when temperatures in the collector approach freezing. This scheme requires automatic valves to dump the water and purge air from the system. Often a larger pump will be required to overcome the system head and re-prime the collectors. A way to avoid automatic (solenoid) valves is to drain the collectors whenever the pump shuts off. This still requires a larger pump. Three-way valves exist that can use city water pressure to reprime the system; otherwise pumps must be used. Some drainback systems only drain the water to a small tank near the collectors thus requiring only a small additional pump. Heat exchangers may be required to separate potable water from

nonpotable water.

**2.1.7.2 HEAT TAPES** - Electric resistance heat tapes are thermostatically activated to heat the water. This scheme requires extra energy and is not completely reliable.

Insertion of heat tapes into preconstructed collectors may be difficult.

**2.1.7.3 RECIRCULATION METHOD** - In this method the control system of Figure 2-4 merely turns on the pump if freezing approaches. In this way, warm water from storage circulates through the collectors until the freezing condition is over. The only extra component needed is a freeze sensor on the collector which is a minimum cost item. However, by circulating heated water, the capacity of storage decreases and less is available the following day. This method is probably the most reliable of the three since it does not depend on additional electrical valves or heating tape, provided that back up power is available to operate pumps in the event of power failure. If the preceding methods are not acceptable or if the choice of water is not acceptable due to concern about corrosion, then a heat transfer fluid must be used. The heat transfer fluid must be used with a heat exchanger in a "closed--loop" configuration as shown in Figure 2-4. The configuration shown in Figure 2-4 will be from 10%-25% less efficient due to the temperature penalty associated with the heat exchanger and the low specific heat of the heat transfer fluid as compared to water. Note an additional pump is also required. If the heat transfer fluid is toxic or non-potable (such as antifreeze) then a double-walled heat exchanger must be used for protection. The different types of heat exchangers are explained in Figure 2-5. It is difficult to estimate the most cost effective freeze protection method. Some studies have shown that for many areas in the U.S., the recirculation method is best particularly where freezing days are few in number. It tends to have the lowest capital cost and energy use cost. However, all the methods except heat transfer fluids rely on the presence of electricity to operate. A simultaneous electrical failure and freezing condition would result in potential failure of the systems. An exception is that new thermally actuated draindown valves are becoming available to replace the sometimes troublesome solenoid valves. Therefore, the absolute safest system would be the nonfreezing heat transfer fluids and these might be considered for the very cold parts of the country (Boston, Chicago, etc.). Each potential project should be considered individually using local weather criteria, freeze protection capital costs,

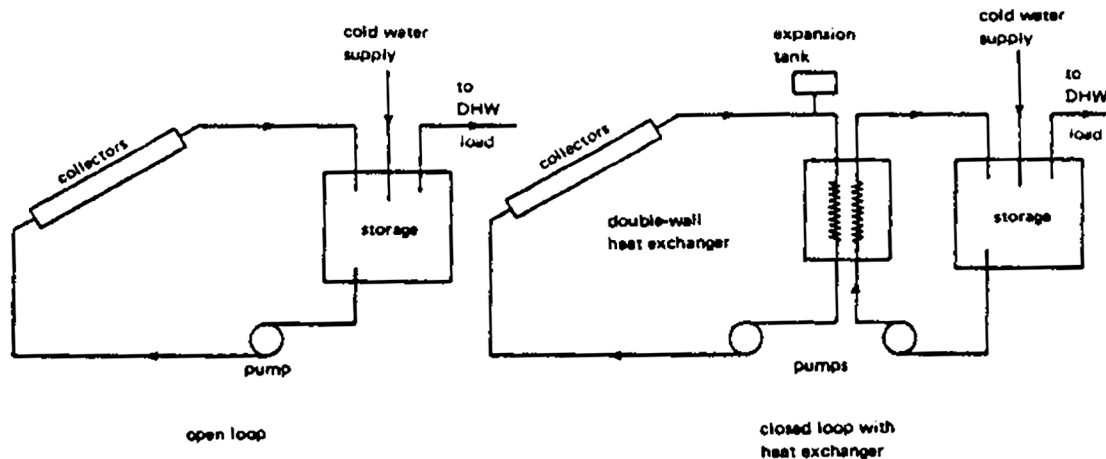

Figure 2-4

### Typical configurations for solar water heater systems

additional energy to run the system, reliability, maintenance, and type of system as the criteria. Often a detailed computer simulation would be required to choose. However, any of the methods will provide some degree of protection. If heat transfer fluids are selected for corrosion or freeze protection, the following paragraphs discuss pertinent criteria. Most heat transfer fluids contain some degree of toxicity. To minimize the probability of contamination of potable water systems the following items should be addressed in any specification or bid:

- Assurances to preclude the possibility of cross connection of potable water piping with heat transfer fluid piping. The use of tags, color coding, different pipe connections, etc, are suggestions.
- Hydrostatic testing of system to find leaks.
- Color indicators in heat transfer fluid to find leaks.
- Safe designs for heat exchangers as given in Figure 2-5.
- Determine toxicity classification of heat transfer fluids. Suggested categories as a minimum are:
  - Oral toxicity (ORAL LD<sub>50</sub>)
  - Carcinogenic.
  - Ocular irritant (eye).

- Dermal irritant (skin).

Before heat transfer fluids are discussed, a review of basic corrosion theory is in order. The two types of corrosion which cause the most damage in solar systems are galvanic and pitting corrosion (Eyre, 1978). Galvanic corrosion is a type of corrosion which is caused by an electrochemical reaction between two or more different metals in contact with each other. A chemical reaction between the metals causes a small electrical current which erodes material from one of the metals. Solar energy systems generally contain a number of different metals such as aluminum, copper, brass, tin, and steel. This makes the solar system a prime candidate for galvanic corrosion. If the dissimilar metals are physically joined or if they are contacted by a common storage or heat-transfer fluid, the possibility of galvanic corrosion becomes much greater. Pitting corrosion is a highly localized form of corrosion resulting in deep penetration at only a few spots. It is one of the most destructive forms of corrosion because it causes equipment to fail by perforation with only a very small weight loss. When heavy metal ions such as iron or copper plate on a more anodic metal such as aluminum, a small local galvanic cell can be formed. This corrosion spot or "pit" usually grows downward in the direction of gravity. Pits can occur on vertical surfaces, although this is not as frequent. The corrosion pits may require an extended period (months to years) to form, but once started they may penetrate the metal quite rapidly. Heavy metal ions can either come as a natural impurity in a water mixture heat transfer fluid or from corrosion of other metal parts of the solar system. Pitting corrosion has the same mechanism (concentration cell) as crevice corrosion thus it can also be aggravated by the presence of chloride or other chemicals which can be part of the water mixture or a contaminant from solder fluxes. Aluminum is very susceptible to pitting corrosion, while copper generally is not. There are several preventive measures which will eliminate or at least minimize galvanic and pitting corrosion in collector systems which use an aqueous collector fluid. The best method to prevent galvanic corrosion is to avoid using dissimilar metals. Where this is not possible or practical, the corrosion can be greatly reduced by using nonmetallic connections between the dissimilar metals, thus isolating them. Galvanic protection in the form of a sacrificial anode is another method of protecting the

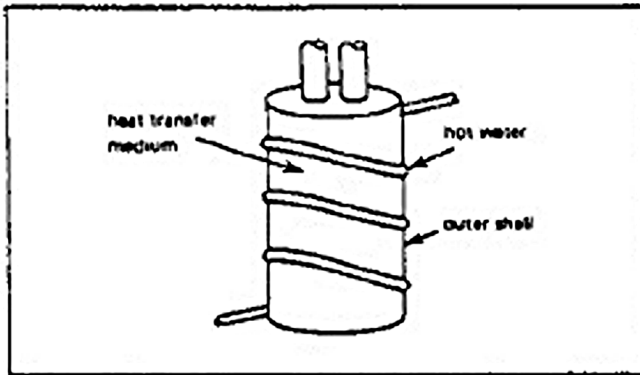

**Double Wall.** Another method of providing a double separation between the transfer medium and the potable water supply consists of tubing or a plate coil wrapped around and bonded to a tank. The potable water is heated as it circulates through the coil or through the tank. When this method is used, the tubing coil must be adequately insulated to reduce heat losses.

**Shell and Tube.** This type of heat exchanger is used to transfer heat from a circulating transfer medium to another medium used in storage or in distribution. Shell and tube heat exchangers consist of an outer casing or shell surrounding a bundle of tubes. The water to be heated is normally circulated in the tubes and the hot liquid is circulated in the shell. Tubes are usually metal such as steel, copper or stainless steel. A single shell and tube heat exchanger cannot be used for heat transfer from a toxic liquid to potable water because double separation is not provided and the toxic liquid may enter the potable water supply in a case of tube failure.

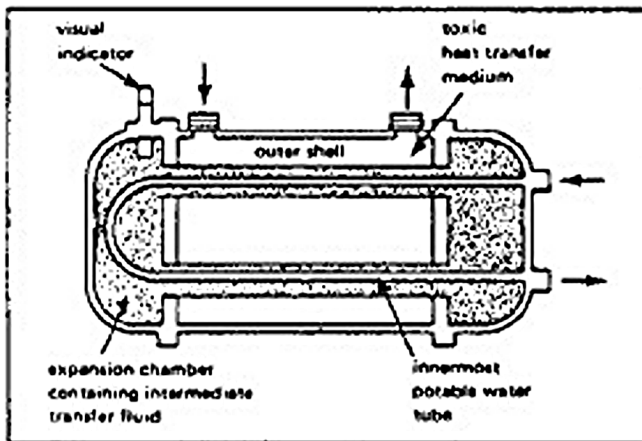
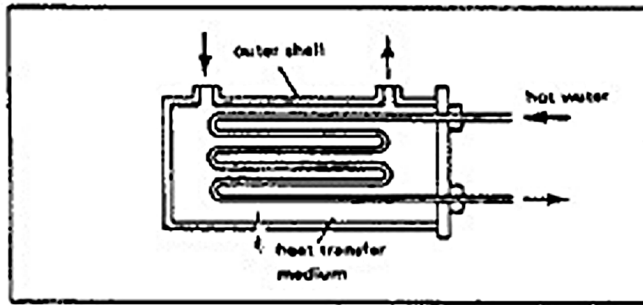

**Shell and Double Tube.** This type of heat exchanger is similar to the previous one except that a secondary chamber is located within the shell to surround the potable water tube. The heated toxic liquid then circulates inside the shell but around this second tube. An intermediary nontoxic heat transfer liquid is then located between the two tube circuits. As the toxic heat transfer medium circulates through the shell, the intermediary liquid is heated, which in turn heats the potable water supply circulating through the innermost tube. This heat exchanger can be equipped with a sight glass to detect leaks by a change in color—toxic liquid often contains a dye—or by a change in the liquid level in the intermediary chamber, which would indicate a failure in either the outer shell or intermediary tube lining.

Figure 2-5

Heat exchangers for solar water heating systems

parent metals. Also, use of similar metals reduces the problems of fatigue failure caused by thermal expansion. Pitting corrosion is essentially eliminated if copper absorber plates are used. Corrosion inhibitors can minimize pitting corrosion in aluminum absorbers. The types of heat transfer fluids available may be divided into two categories, nonaqueous and aqueous. Silicones and hydrocarbon oils make up the nonaqueous group, while the aqueous heat transfer fluids include untreated potable (tap) water, inhibited-distilled water, and inhibited glycol/water mixtures. The potable tap water and inhibited distilled water do not, of course, offer freeze protection. Table 2-5 shows characteristics of some of the most common heat transfer fluids.

**2.1.7.1 SILICONE FLUIDS.** Silicone heat transfer fluids have many favorable properties which make them prime candidates for collector fluids. They do not freeze, boil, or degrade. They do not corrode common metals, including aluminum. They have excellent stability in solar systems stagnating under 400 deg. F. Silicone fluids are also virtually nontoxic and have high flash and fire points. Current evidence indicates that silicone fluids should last the life of a closed-loop collector system with stagnation temperatures under 350 deg. - 400 deg. F. The flash point is fairly high, 450 deg. F, but since the HUD standards state that heat transfer fluids must not be used in systems whose maximum stagnation temperature is less than 100 deg. F lower than the fluid's flash point, this limits most silicone oils to systems with a maximum temperature of 350 deg. F or less. Also silicones do not form sludge or scale, so system performance does not decrease with time. The main drawback of silicone fluids is their cost. Thus the cost of the 20 to 30 gallons of collector fluid required for a typical 500 ft<sup>2</sup> collector system becomes considerable. As with hydrocarbon oils, the lower heat capacity and higher viscosity of silicone fluid requires larger diameter and more expensive piping. Due to the higher viscosity, larger pumps will be required and subsequent higher pumping costs. One other problem with silicone fluids is the seepage of fluid at pipe joints. This problem can be prevented by proper piping installation and by pressurizing the system with air to test for leaks. There have also been reports of seepage past the mechanical seals of circulating pumps. The use of magnetic drive or canned wet rotor pumps when available in the proper size is a method of avoiding mechanical seal leakage. Silicones have the advantage of lasting the life of the system with little

maintenance. While this helps minimize operating expenses, the initial cost of silicones is markedly higher than that of other available heat transfer fluids. However, the high initial cost of silicone heat transfer fluid may be less than the savings that result from minimum maintenance and no replacement of collector fluid. The use of silicone fluid allows absorbers with aluminum fluid passages to be used without fear of corrosion. The savings gained from the use of aluminum absorbers as opposed to copper absorbers could be substantial.

**2.1.7.2 HYDROCARBONS.** Hydrocarbon oils, like silicones, also give a long service life, but cost less. They are relatively noncorrosive, nonvolatile, environmentally safe, and most are nontoxic. They are designed for use in systems with lower operating temperatures, since some brands break down at higher temperatures to form sludge and corrosive organic acids. Typical closed-cup flashpoints run from 300 deg. F to 420 deg. F, but the fluids with higher flashpoints have a higher viscosity. The HUD bulletin on minimum property standards for solar heating systems recommends a closed-cup flashpoint 100 deg. F higher than maximum expected collector temperatures. Unsaturated hydrocarbons are also subject to rapid oxidation if exposed to air, necessitating the use of oxygen scavengers. Some hydrocarbons thicken at low temperatures and the resultant higher viscosity can cause pumping problems. Newer hydrocarbons are being developed which do not harm rubber or materials of construction, since this has been a problem with hydrocarbons. In general, they cannot be used with copper, as it serves as a catalyst to fluid decomposition. The thermal conductivity of hydrocarbons is lower than that of water, although the performance of some brands is much better than others. The cost of typical hydrocarbon and other synthetic heat transfer oils vary. A typical liquid collector of 500 ft<sup>2</sup> plus the piping to and from storage will require from 20 to 30 gallons of collector fluid. The lower heat capacity and higher viscosity of these oils will also require larger diameter pipe, increasing materials costs further. If hydrocarbon fluids are used, the additional capital cost should be compared with expected savings due to lower maintenance costs. The use of aluminum absorbers rather than copper absorbers will also result in substantial savings.

**2.1.7.3 DISTILLED WATER.** Distilled water has been suggested for use in solar collectors since it avoids some of the problems of untreated potable water. First, since

the distillation process removes contaminants such as chlorides and heavy metal ions, the problem of galvanic corrosion, though not completely eliminated, should be alleviated. However, distilled water is still subject to freezing and boiling. For this reason, an anti-freeze/anti-boil agent such as ethylene glycol is often added.

**2.1.7.4 WATER-ANTI-FREEZE.** Nonfreezing liquids can also be used to provide freeze protection. These fluids are circulated in a closed loop with a double wall heat exchanger between the collector loop and the storage tank (see Figure 2-5).

Water/antifreeze solutions are most commonly used because they are not overly expensive. Ethylene and propylene glycol are the two most commonly used antifreezes. A 50-50 water/glycol solution will provide freeze protection down to about -30 deg. F, and will also raise the boiling point to about 230 deg. F. The use of water/glycol solution presents an additional corrosion problem. Water glycol systems will corrode galvanized pipe. At high temperatures glycols may break down to form glycolic acid. This breakdown may occur as low as 180 deg. F and accelerate at 200 deg. F. This acid corrodes most all metals including copper, aluminum, and steel. The rate of glycol decomposition at different temperatures is still a subject of uncertainty. The decomposition rate of glycol varies according to the degree of aeration and the service life of the solution. Most water/glycol solutions require periodic monitoring of the pH level and the corrosion inhibitors. The pH should be maintained between 6.5 and 8.0. Replacement of the water/glycol solution may be as often as every 12-24 months or even sooner in high temperature systems. If these solutions are used in the collector loop, the seller should specify the expected life of the solution and the amount of monitoring required. The cost of periodic fluid replacement and monitoring should be considered in the economic analysis. Since glycol-water mixtures do require a lot of maintenance (and since users can be quite negligent) it is recommended that glycols not be used in family housing solar heating and DHW systems, and that glycol-water solutions be reserved for use in large-scale installations which have regular maintenance schedules and where the high cost of silicone oils would be prohibitive.

**2.1.8 COLLECTOR CONNECTIONS.** Water flow through non-horizontal collectors should always be against gravity, except in trickle-type collectors. Usually this means



water inlet to the collector at the bottom, and outlet at the top. Care must be taken so that equal flow goes to all collectors. If the pipe manifold pressure drop is large, then end collectors will get little flow. The design most usually used is one in which the collectors are connected in parallel. This results in low pressure drop and high efficiency of each collector. A series hookup results in the highest temperature and the highest pressure drop but lowest collector efficiency. Higher temperatures than in the parallel arrangement may be obtained with parallel-series connections, but at the expense of reduced efficiency and greater cost. These high temperatures are not usually required for hot water and space heating. Figure 2-6 shows different connection configurations. All collector systems should be installed using a reverse-return (Z flow) piping layout as shown in figure 2-6a. Up to about 12 collectors in a row can be accommodated. Very large installations may merit computer simulations to optimize the flow balance of each stage.

**2.1.9 COLLECTOR EFFICIENCY AND HEAT LOSSES.** In the preceding sections, many details as to the construction and choice of components of a solar collector have been given. All of these features contribute to how well a collector will perform or how efficient it will be. Solar collectors, depending on their construction and materials, suffer from several kinds of heat losses. They can lose heat by convection of wind blowing over their top and bottom surfaces. As the collector temperature increases above the temperature of the surrounding air, the radiation heat losses increase. This results in lower heat collected (lower efficiency) at higher collector temperatures. Heat can be lost by conduction from the back and sides of a collector. To evaluate the effects of all these parameters individually would involve detailed and difficult calculations. Fortunately, collector performance can be compared much more easily by a single graph depicting collector efficiency versus the parameter  $\Delta T/l$ . collector efficiency is defined as the ratio of the heat collected to the insolation (I) falling on the surface of the collector. Also:

$$\Delta T = T_i - T_a$$

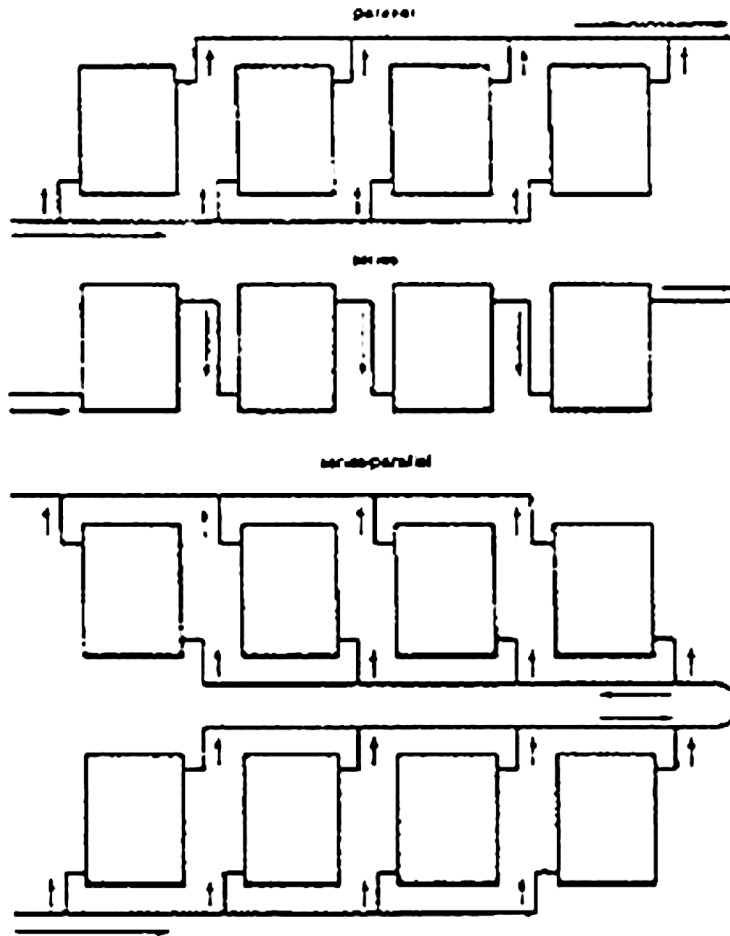

Figure 2-6  
 Connection Schemes for Solar Heating Systems

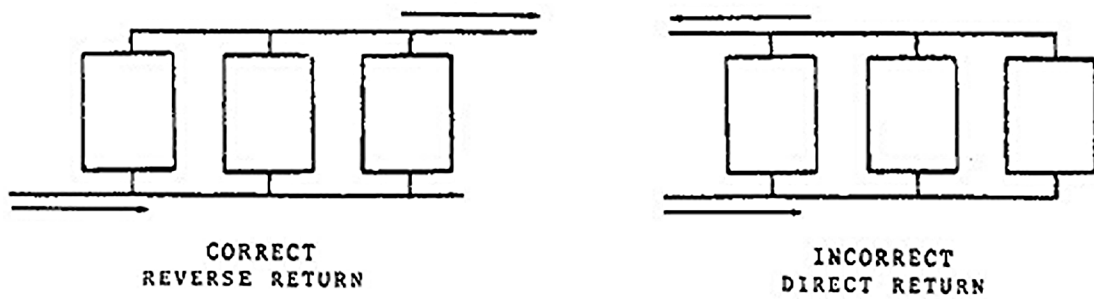

Figure 2-6a  
 Collector Piping

where

$T_i$  = temperature of fluid entering collector (inlet).

$T_a$  = ambient air temperature.

Figure 2-7 gives the efficiency of some typical flat plate solar collectors. The most efficient solar collector would convert 100% of the sun's energy falling on it to usable heat. As shown in Figure 2-7, this is impossible so the designer looks for a collector that converts the greatest percentage of solar energy to heat, at the required temperature, and at the lowest cost. It is important that each collector be tested according to an exacting standard. The early standard for testing solar collectors, was NBSIR 74-635 published by the National Bureau of Standards. This is the standard the previous edition of this report used to report collector efficiencies. Subsequently, the American Society of Heating, Refrigerating, and Air Conditioning Engineers, Inc. (ASHRAE) sponsored the development of a uniform method of testing solar collectors to form the preliminary standard 93-P and finally the version in use today, ASHRAE Standard 93-77, "Methods of Testing to Determine the Thermal Performance of Solar Collectors." This method uses the Hottel-Whillier equation and is generally accepted in the solar industry. The differences between the NBS and the ASHRAE standard are as follows:

- ASHRAE requires the use of gross collector area rather than aperture or net area used in NBS.
- ASHRAE uses the collector inlet temperature as one of its parameters whereas NBS uses the average absorber plate temperature defined as the sum of the inlet and outlet temperatures divided by two.

In general, the NBS standard will give higher collector efficiencies, possibly 5%-10%, but the accepted consensus standard at this time is ASHRAE Standard 93-77. The Department of Energy (DOE) is using the ASHRAE standard in developing its program for national certification and rating of solar collectors. Therefore, all data given in this report and future reports will conform to the ASHRAE standard. Figure 2-7 shows many contemporary solar collectors as of the writing of this course. Data is from ASHRAE 93-77 tests.

No.	Description	Ref Table 2-6
1	Single glass-alum plate	6
2	Single glass-copper plate-selective	22
3	Double glass-copper plate-selective	107
4	Single plastic-copper tube on alum plate	28
5	Unglazed-rubber plate	13
6	Single glass-copper-selective-evacuated	N/A

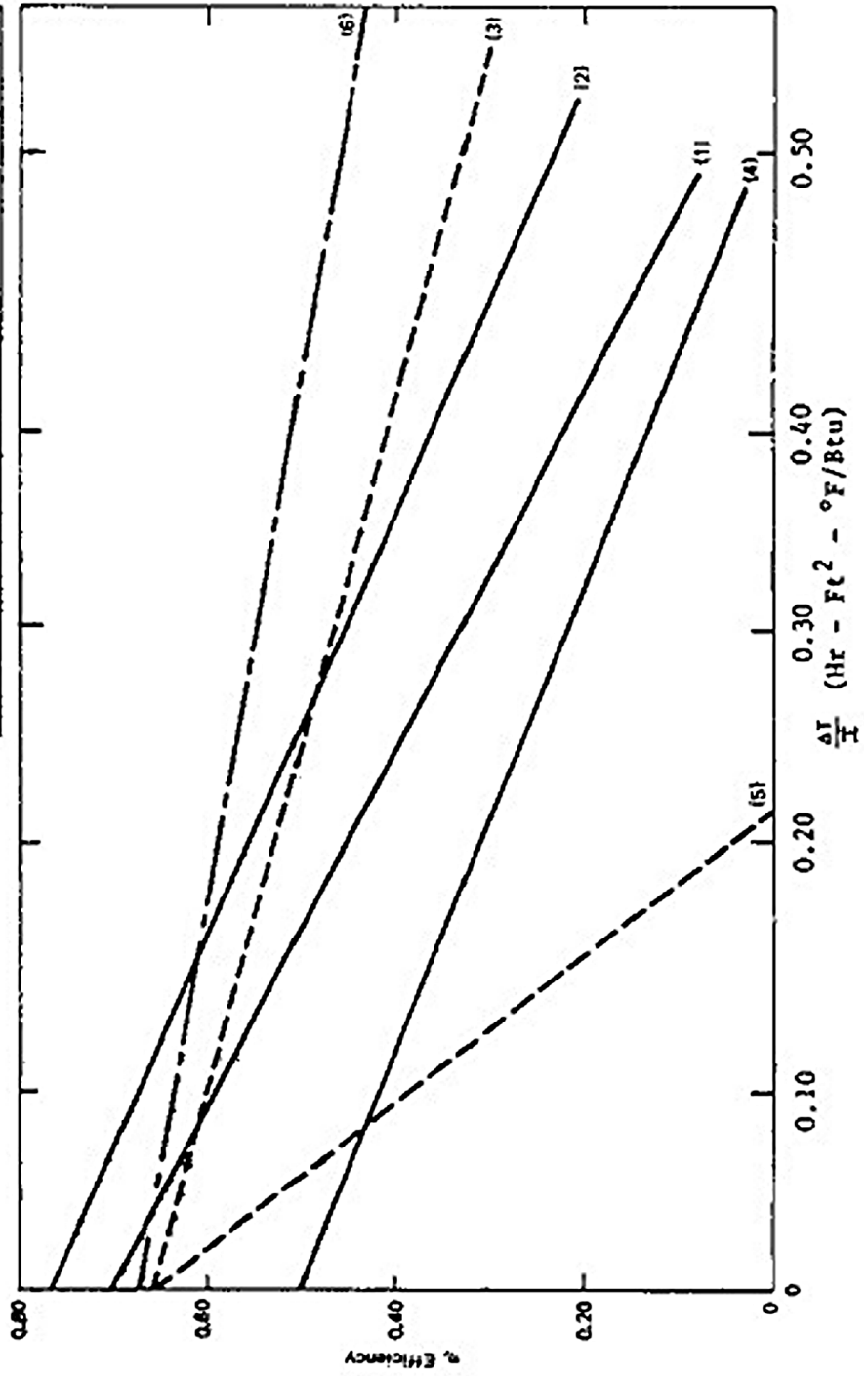

Figure 2-7  
Typical Solar Collector Efficiencies

A large amount of test data on solar collectors is becoming available through the national certification program run by SEIA, the NCEL tests, and individual laboratories testing for the manufacturers. The National Certification Program managed by SEIA is now the primary source of solar collector test data. Table 2-6 represents a random sampling of the many solar collectors available. It is not a comprehensive list nor is it an endorsement of any particular collector. These data were excerpted from the Solar Rating and Certification Program of SEIA, July 1983 Edition. The main criteria for each collector in Table 2-6 is that it have an accepted ASHRAE 93-77 performance test. Other than that, collectors were chosen to provide a variety of types, materials, construction techniques, geographical locations, and cost information. A few cautions are advisable. Prices may be up to one year old from the publication date and should be checked if a purchase is anticipated. Manufacturers may have other models available. For example, Table 2-6 may give details for a single glazed collector and chances are the manufacturer would also have a double glazed model with valid ASHRAE 93-77 test data. The user may know of other collectors with test data available. These could be readily compared to similar models in Table 2-6. To select a collector from Table 2-6, first note that collectors constructed of similar materials (copper, aluminum, etc.) are grouped together. Then, it is necessary to pay attention to the y-intercept (called efficiency intercept in Table 2-6) which gives the highest efficiency of a collector, and the slope which gives a measure of the rate at which the collector efficiency decreases. These parameters will be used later in estimating the solar collector performance. In general the more negative the slope, the less efficient the collector. However, this must be balanced with the value of the efficiency intercept. For example, in Figure 2-7 and Table 2-6 note that double glazed collectors start out at a lower instantaneous efficiency (y intercept) but do not lose efficiency very fast (less negative slope) so that when comparing with single glazed collectors the operating temperature ( $T_i$ ) will ultimately determine which is best (see Table 2-4 also). When the cost of the collector is also considered, it becomes very difficult to "intuitively" pick a best collector in Table 2-6. The user should consider several options of collectors when using the worksheets in the later sections. In choosing a collector, Figure 2-7 should be used only for qualitative

Item	Model No.	GLASS TYPE		Absorber Material		Efficiency, %	Range of Collector Area, sq ft	Area of Collector, sq ft	Cost per sq ft, \$	Absorber Material	Manufacturer
		Single	Double	Collector	Selector						
<b>ALUMINUM ABSORBER COLLECTORS</b>											
1	Spectra 22	Glass		X		0.564	-1.3625	24.22		Aluminum	Energy Marketing Group, Inc. Palm Beach, FL
2	22	Film Lamin		X		0.6361	-1.1628	28.22		Aluminum	Green Systems Solar, Inc. Jacksonville, FL
3	8-100	Polycarbonate		X		0.5671	-1.360	27.88		Aluminum	Positive Energy Products, Inc. Houston, TX
4	1004	Polyester		X		0.6406	-0.9665	21.00		High Purity Aluminum	Raytheon Solar Company Birmingham, AL
5	1555	Glass		X		0.7313	-1.6225	41.71		High Purity Aluminum	Raytheon Solar Company Pittsburgh, PA
6	1661C	Glass		X		0.6876	-1.2679	24.26		Aluminum	Solar Systems of California Irvine, CA
7	Path 23		Lamin (outer) Film (inner)	X		0.5146	-1.1263	15.29		Aluminum	Semiconductor Solar Systems, Inc. 1500 Placette Holliston, MA
8	367	Glass		X		0.6013	-1.2360	18.81		Decorated Aluminum	Seashore Solar Company Toledo, OH
<b>ALUMINUM ABSORBER COLLECTORS</b>											
9	DC 138796	Glass		X		0.7276	-0.8270	24.6	2400	Stainless Steel	American Tanks Corporation Dallas, TX
10	DC 176276	Glass		X		0.7261	-1.1562	21.2		Flashed Steel	American Tanks Corporation Dallas, TX
11	10005	Glass		X		0.7049	-1.2117	18.94		Formed Annealed Plate	Solar Beam Inc., Energy Systems Dallas, TX
12	60744V-4	Flashed Fiberglass reinforced polyester resin		X		0.6789	-0.7772	48.91		Flashed Steel	Chlor Industry Houston, TX
<b>POLYESTER ABSORBER COLLECTORS</b>											
13	5016011 70	Flashed				0.6022	-1.2220	22.99	2369	Rubber	Solar Energy Systems Inc. Ellenville, NY
14	5016011 70	Flashed				0.6029	-1.2461	22.89	16	Rubber	Solar Energy Systems Inc. Ellenville, NY
15	502 100	Glass				0.6072	-1.4761	19.25	600	Rubber	Solar Energy Systems Inc. Ellenville, NY
16	5020 110	Flashed				0.6000	-1.2214	24.94		Plastic	Polysol, Inc. Maple Park, OH

Table 2-6  
Solar Collector Test Results

Item	Model No.	GLASSING TYPE		Absorber Coating		Efficiency Intercept %	Slope of Efficiency Line $\rho$ $\frac{1}{\text{hr}} \cdot \text{m}^2 \cdot \text{m}^2$	Area of One Panel (Square ft)	Cost per Panel \$	Absorber Material	Manufacturer
		Single	Double	Non-Selective	Selective						
<b>FIBER/PLASTIC ABSORBER COLLECTORS</b>											
17	JY (8')	Reinforced polyester				0.6141	-1.7658	24.2		Plastic	Fafco, Inc. - Menlo Park, CA
18	8' Solar Pool Heating Collector	Unglazed				0.7312	-2.3788	32.0		Black Polymer	Mailmark Solar Systems, Inc. - Rolling Meadows, IL
19	IBC-127	Fiberglass reinforced plastic		X		0.5419	-1.0874	16.67		Coiled plastic tube	Solar Research, Inc. - Waterville, GA
20	TES603	Polycarbonate Tedlar solar		X		0.6748	-1.0094	20.08		Extruded polysulfone	Banada Energy Systems, Ltd. - Tampa, FL
21	TP011001	Unglazed				0.8229	-3.6727	39.33		Polycarbonate w/carbon black stabilizer	Banada Energy Systems, Ltd. - Tampa, FL
22	BEI-32	Fiberglass reinforced polyester				0.6191	-1.5668	31.52		Ethylene propylene copolymer	Sealed Air Corp. - Hayward CA
23	FE-40	Unglazed reinforced polyester				0.7738	3.5872	39.38		Ethylene propylene copolymer	Sealed Air Corp. - Hayward CA
<b>COPPER TUBES OR ALUMINUM ABSORBERS</b>											
24	DM-2	Fiberglass		X		0.5910	-2.0079	30.26		Copper on steel	Hennberger - Yuma, AZ
25	EC-2	Glass		X		0.7237	-1.2003	22.77		Copper tube/ aluminum finish	Electra Solar Energy Div. / Alrex Inc. - New York, NY
26	CR-4P	Teflon/ Tedlar		X		0.6283	-0.9760	32.75		Aluminum finish/ copper	Coetti Air Conditioning, Inc. - Phoenix, AZ
27	SOCPSAP1	Tedlar		X		0.6729	-1.1923	32.33		Aluminum finish/ copper tube	Coetti Air Conditioning, Inc. - Phoenix, AZ
28	A.H.V.	Extruded polycarbonate		X		0.5452	-0.8603	29.62		Copper tubes bonded to steel sheet	Hellas Solar Co. - San Valley, CA
29	FWC	Glass		X		0.6445	-1.091	32.0		Aluminum finish/ copper tube	Indal Aluminum Products - Los Angeles, CA
30	FLC	Fiberglass		X		0.6527	-1.2847	32.0		Aluminum finish/ copper tube	Indal Aluminum Products - Los Angeles, CA
31	5000T	Teflon		X		0.7704	-1.3234	14.8		Copper tube/ aluminum finish	International Solar Products Corporation - Monterey Park, CA

Table 2-6 (continued)  
Solar Collector Test Results

Item	Model No.	Glass Type		Absorber Coating		Efficiency Intercept %	Slope of Efficiency Line $\frac{1}{\text{hr-ft}^2-\text{F}}$	Area of One Panel (Gross) ft <sup>2</sup>	Cost per Panel \$	Absorber Material	Manufacturer
		Single	Double	Non-selective	Selective						
COPPER TUBE OR ALUMINUM ABSORBERS											
32	5000C	Glass		X		0.7451	-1.3190	34.7		Copper tube/aluminum finish	International Solar Products Corporation Monterey Park, CA
33	SC 33-P-40-A	Glass		X		0.7826	-1.1098	31.0	\$450	Aluminum finish/copper tube	Saypak, Inc. Westlake Village, CA
34	SC 42-P-40-A	Glass		X		0.7826	-1.1000	41.97	\$567	Aluminum finish/copper tube	Saypak, Inc. Westlake Village, CA
35	SK 1001A	Glass		X		0.7492	-1.0342	44.54		Copper tubing bonded between aluminum sheets	Saypak, Inc. Westlake Village, CA
36	BOGE 11	Glass		X		0.6420	-1.1572	21.3		Copper tube/aluminum sheet	Solohart California San Diego, CA
37	SD-4A	AFC Sunador			X	0.7657	-0.7236	18.52		Welded flared tube, copper	Solar Development Inc. Riviera Beach, FL
38	SE-20	Glass		X		0.6543	-1.1607	31.07		Aluminum finish/copper tube	Solar Edwards, Inc. San Diego, CA
39	C 3	Glass		X		0.6517	-1.1530	15.88		Copper tube/aluminum finish	Solar Heat Corp. Santa Monica, CA
40	SH-30A	Glass			X	0.4257	-1.4221	35.0		Copper tube/aluminum finish	Solar Tech Mfg., Inc. Picoima, CA
41	LSC-D	Glass		X		0.7604	-1.3398	21.89	\$254	Copper tube/aluminum finish	Solteor, Inc., Jordan Solar Energy Systems New York, NY
42	CAP-48-90	Glass		X		0.7146	-1.0785	31.70		Copper tube/aluminum plate	Staghart Industries, Inc. Ontario, CA
43	BBA-38	Glass		X		0.7046	-1.0133	24.19	\$270	Copper tube/aluminum plate	Sunburst Solar Energy Division Aero Energy Corp Elk Grove, CA
44	Suncor IX	Glass		X		0.6772	-1.1731	18.53		Copper tube/aluminum finish	SUNCOR, Inc. Tempe, AZ

Table 2-6 (continued)  
Solar Collector Test Results



Item	Model No.	Glazing Type		Absorber Coating		Efficiency Intercept %	Slope of Efficiency Line $\frac{1}{2} \frac{1}{\sin \theta} - (1 - \eta)$	Area of One Panel (Gross) ft <sup>2</sup>	Cost per Panel \$	Absorber Material	Manufacturer
		Single	Double	Non-selective	Selective						
COPPER TUBES OR ALUMINUM ABSORBER											
45	PPS-3476	Class		X		0.6772	-1.1731	18.93		Copper tube/ aluminum finish	Sun Devil Solar Collector Works Mesa, CA
46	SE302	Class		X		0.7495	-1.4557	30.7		Aluminum finish/ copper tube	Gen Systems Phoenix, AZ
47	C-40	Class		X		0.6787	-0.9554	40.34		Aluminum finish/ copper tube	Sun-Mat Solar Systems Phoenix, AZ
48	Janlar 32	Class		X		0.7585	-1.7023	33.94		Copper tube/ aluminum finish	Urja, Inc. Santa Ana, CA
49	AP-32 SV/30	Class		X		0.8248	-1.3016	32.0	\$10.90 to \$15.25 per ft <sup>2</sup>	Copper tube/ aluminum finish	US Solar Corp. Hampton, FL
50	AP-24-00		Class	X		0.7076	-0.7385	24.55	\$10.90 to \$15.25 per ft <sup>2</sup>	Copper tube/ aluminum finish	US Solar Corp. Hampton, FL
51	SM-11	Class			X	0.6858	-1.1457	20.00		Copper tube/ aluminum finish	Solar Unlimited, Inc. Huntsville, AL
ALL COPPER ABSORBERS											
52	HO301-7L	Class			X	0.7593	-0.9114	31.87	\$525 to \$645	Copper	AcroSun Industries, Inc. Hollister, CA
53	A-3	Class			X	0.7751	-0.8699	19.11		Copper	Aircraftman Millbrook, AL
54	BOLCAN 3	Tedlar		X		0.6436	-0.3970	15.21		Copper pipe	Albuquerque Western Solar Industries, Inc. Albuquerque, NM
55	A 1171 C	Class			X	0.7499	-0.7283	24.35		Copper	Associate Solar Systems, Inc. Lake Havasu City, AZ
56	CAL 40	Class		X		0.7348	-1.1253	46.56		Copper	Alternate Energy Distributors Renoirville, CA
57	3200	Class			X	0.7060	-0.8233	32.2		Copper	American National Energy Corp. San Diego, CA
58	SE 11	Class			X	0.7444	0.7195	27.94		Copper	American Solar King Corporation Mado, TX

Table 2-6 (continued)  
Solar Collector Test Results

Item	Model No.	Glass Type		Absorber Coating		Efficiency Intercept %	Slope of Efficiency Line $\frac{\%}{\text{Btu/hr-ft}^2-\text{F}}$	Area of One Panel (Gross) ft <sup>2</sup>	Cost per Panel \$	Absorber Material	Manufacturer
		Single	Double	Non-selective	Selective						
ALL COPPER ABSORBERS											
59	903-4	Glass			X	0.6605	-0.7652	24.81		Copper	American Sun-systems, Inc. Milford, CT
60	D-477	Glass			X	0.7202	-0.7680	33.08	8500	Copper	Ametek, Inc Power Systems Div Ivyland, PA
61	Sun-tracker 3	Collech reflective surface			X	0.5120	-0.4430	20.91		Copper parabolic concentrator	Applied Solar Resources Phoenix, AZ
62	EL 4875	Tedlar			X	0.7544	-1.2223	30.8		Copper	Cal West Energy Services, Inc. Palos Verdes Estates, CA
63	EL 4810	Glass			X	0.7328	-1.1231	30.8		Copper	Cal West Energy Services, Inc. Palos Verdes Estates, CA
64	C-147C	Glass			X	0.7774	-0.8548	31.81	8495	Copper	Colt, Inc. Paso Robles, CA
65	C-147P	Glass			X	0.7442	-1.0498	31.91		Copper	Colt, Inc. Paso Robles, CA
66	SE-18	Glass			X	0.7579	-0.7306	37.29		Copper	Fafco, Inc. Menlo Park, CA
67	323	Glass			X	0.7823	-0.9243	31.47		Copper	International Solar Panel Inc. Fort Collins, CO
68	Royal II	Glass			X	0.7235	-1.0419	24.62		Copper	King Energy Systems, Inc. Irvine, CA
69	9303	Glass			X	0.7251	-0.7670	32.64		Copper	Monagan, Ltd. Gaitherburg, FL
70	MUDC-724	Glass			X	0.6678	1.1176	25.16		Copper	Mer-Ple Industries, Inc. Cleveland, OH
71	SPSC-730	Tedlar			X	0.6109	-1.1257	31.24		Copper	Mer-Ple Industries, Inc. Cleveland, OH
72	SC 3274-P	Glass			X	0.6823	-1.1501	32.04		All copper	Merthrup, Inc. Hutchison, TX
73	48C	Glass			X	0.7230	-1.1084	24.36	8413	All copper	Nevan Energy, Inc. Boulder, CO
74	37	Glass			X	0.6978	-1.168	32.29		Copper	Parker International Corp. Los Alamitos, CA
75	406C	Glass			X	0.7099	-0.8083	29.8		Copper	Radco Products, Inc. Santa Maria, CA

Table 2-6 (continued)  
Solar Collector Test Results

Item	Model No.	Glass Type		Absorber Coatings		Efficiency Intercept %	Slope of Efficiency Line $\frac{1}{\text{hr-ft}^2-\text{F}}$	Area of Conv. Panel (Crago) $\text{ft}^2$	Cost per Panel \$	Absorber Material	Manufacturer
		Single	Double	Non-selective	Selective						
ALL COPPER ABSORBERS											
76	TK15503	Polycarbonate/Yodhar filter			X	0.7391	-1.0669	38.96		Copper	Rehman Energy Systems, Ltd. Phoenix, AZ
77	3G 33-SMC-2W	Glass			X	0.7203	-0.7819	32.02	\$532	Copper	Raypak, Inc. Westlake Village, CA
78	0-11	Glass			X	0.7354	-1.0281	18.8		Copper	Revere Solar & Architectural Products, Inc. Rome, NY
79	325, 311480	Glass			X	0.7362	-0.7490	33.08		Copper	Seare, Reebuck, & Company Chicago, IL
80	80795 (4K10)	Glass			X	0.7325	0.8964	40.5		Copper	Solar Development Inc. Riviera Beach, FL
81	29201	Yodhar			X	0.606	0.326	14.76		Copper parabolic concentrator	Solar Resources International Phoenix, AZ
82	366	Glass			X	0.7286	-1.1622	24.50		Copper	Solar Shelter, Inc. Denver, CO
83	STB-JDM	Glass			X	0.7315	-0.8316	32.91		Copper	Solar Tech Mfg., Inc. Pacoima, CA
84	MP432	Glass			X	0.7677	-0.8428	47.93		Copper	Solar Transition, Inc. San Diego, CA
85	APC-48-2				X	0.7449	-2.2097	30.22		Textured copper coil	Sunburst Solar Energy Division Aero Energy Corp. Elk Grove, CA
86	BEAC 48	Glass			X	0.7022	-0.7238	32.92	\$675	Copper	Sunburst Solar Energy Division Aero Energy Corp. Elk Grove, CA
87	BEAC 38	Glass			X	0.7143	-1.0331	26.79	\$465	Copper	Sunburst Solar Energy Division Aero Energy Corp. Elk Grove, CA
88	IV	Glass			X	0.7317	0.6756	23.83		Copper	Sundor, Inc. Tempe, AZ
89	CP-3496	Glass			X	0.6444	-1.1818	23.69		Copper	Sun Devil Solar Collector Works Mesa, AZ
90	SI 52-DBC	Glass			X	0.7845	-0.8658	31.33		Copper	Sun Earth of California Petaluma, CA
91	039814 25	Glass			F	0.77	1.066	21.0		Parabolic concentrator	Sun Power Systems Sunnyvale, CA

Table 2-6 (continued)  
Solar Collector Test Results

Spec	Model No.	GLASS TYPE		ABSORBER COATING		Efficiency Intercept %	Slope of Efficiency Line $\frac{1}{\text{RMSE}} - F$	Area of One Panel (Gross) $\text{ft}^2$	Cost per Panel \$	Absorber Material	Manufacturer
		Single	Double	Non-selective	Selective						
ALL COPPER ABSORBERS											
92	SL-3010	Class		X		0.7729	-1.1231	26.04		Parabolic concentrator	Sun Resource Energy Systems Van Nuys, CA
93	V4896-TF	Class		X		0.7340	-1.1253	32.40		Copper	Sunstate Energy Systems, Inc. San Marcos, CA
94	146-SC	Class		X		0.7401	-1.0991	32.06		Copper	SunTherm Corp. Sylmar, CA
95	248C-112	Class		X		0.7283	-1.1031	19.25		Copper	Sunwest Energy, Inc. Redding, CA
96	L-45	Class			X	0.7138	-0.7088	31.66		Copper	Sunworks, Inc. Commerville, NJ
97	SL4810	Class		X		0.7729	-1.1231	30.80		Copper	Urjo, Inc. Santa Ana, CA
98	323	Class			X	0.7823	-0.9243	31.47		Copper	United Solar Association, Inc. Denver, CO
99	CPY-71-80C	Class			X	0.7457	-0.8757	19.81		Copper	US Solar Corp. Hampton, FL
100	WRD-7-31	Class		X		0.7297	-1.1461	31.41		Copper	Western Solar Development, Inc. Vacaville, CA
101	1000	Class		X		0.7444	-0.7195	31.5		Copper	Daystar Corp. Burlington, MA
102	520 (4XB)	Class		X		0.6998	-1.3076	31.8		Copper	International Solar Products, Corp. Monterey Park, CA
103	323	Class			X	0.7823	-0.9243	31.42		Copper	Pacific Resources, Inc. Honolulu, HI
104	PS-030	Un glazed		X		0.7853	-0.7926	29.93		Copper	Purex Pool Products, Corp. Industry, CA
105	GPS-030	Tedlar		X		0.6109	-1.1237	31.24		Copper	Purex Pool Products, Corp. Industry, CA
106	MMSG-724	Class		X		0.6567	-0.9236	25.83		Copper	Purex Pool Products, Corp. Industry, CA
107	MHC-724		Class	X		0.6478	-1.1376	25.16		Copper	Purex Pool Products, Corp. Industry, CA
108	BCC-37	Class			X	0.7532	-0.7836	32.73		Copper	Solarstia Corporation Northbrook, IL
109	L-25P	Class		X		0.7332	-1.2511	25.46		Copper	Sunwest Solar Systems, Inc. Phoenix, AZ

Table 2-6 (continued)  
Solar Collector Test Results

No.	Description	Ref Table 2-6
1	Single glass-alum plate	6
2	Single glass-copper plate-selective	22
3	Double glass-copper plate-selective	107
4	Single plastic-copper tube on alum plate	28
5	Etglazed-fibber plate	13
6	Single glass-copper-selective-encased	N/A

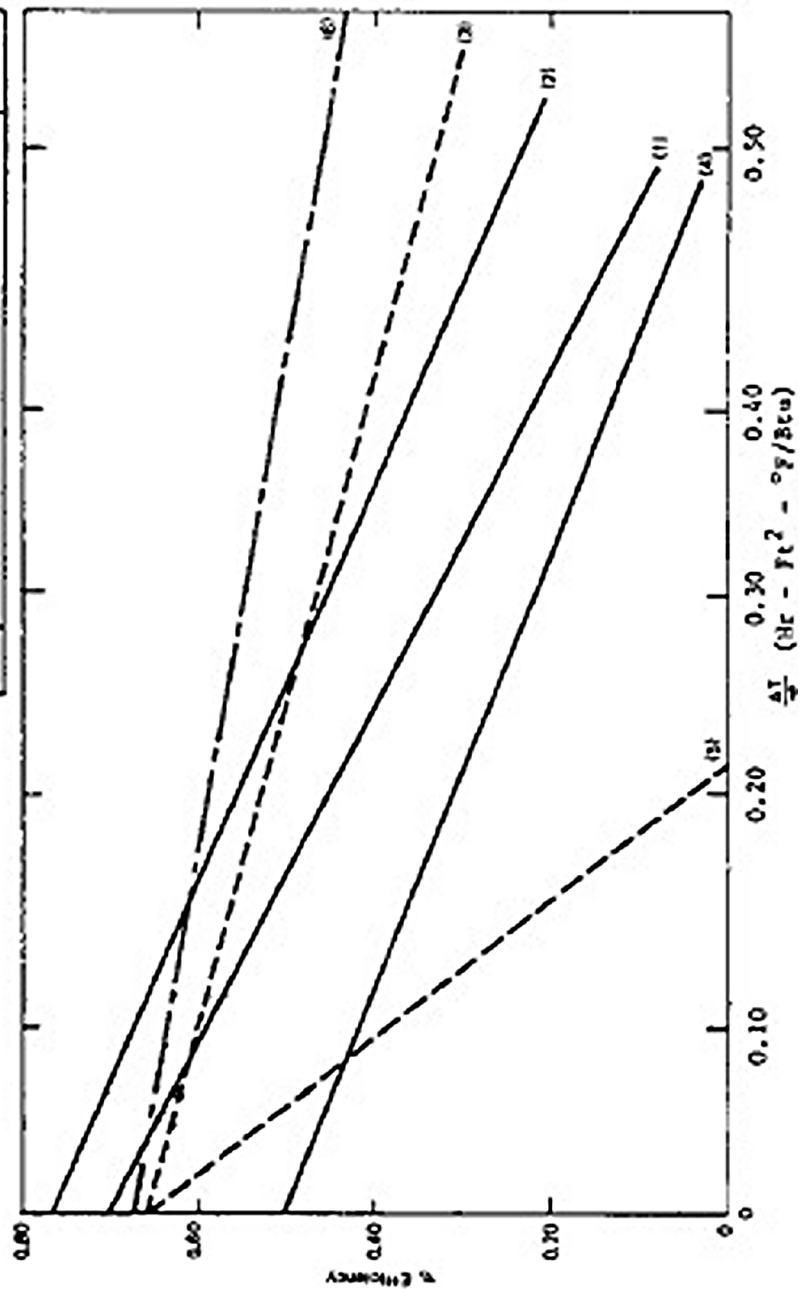

Figure 2-7  
Typical Solar Collector Efficiencies

judgments, while Table 2-6 should be used for typical slope and intercept values. This avoids the errors associated with trying to "read off" numbers on Figure 2-7.

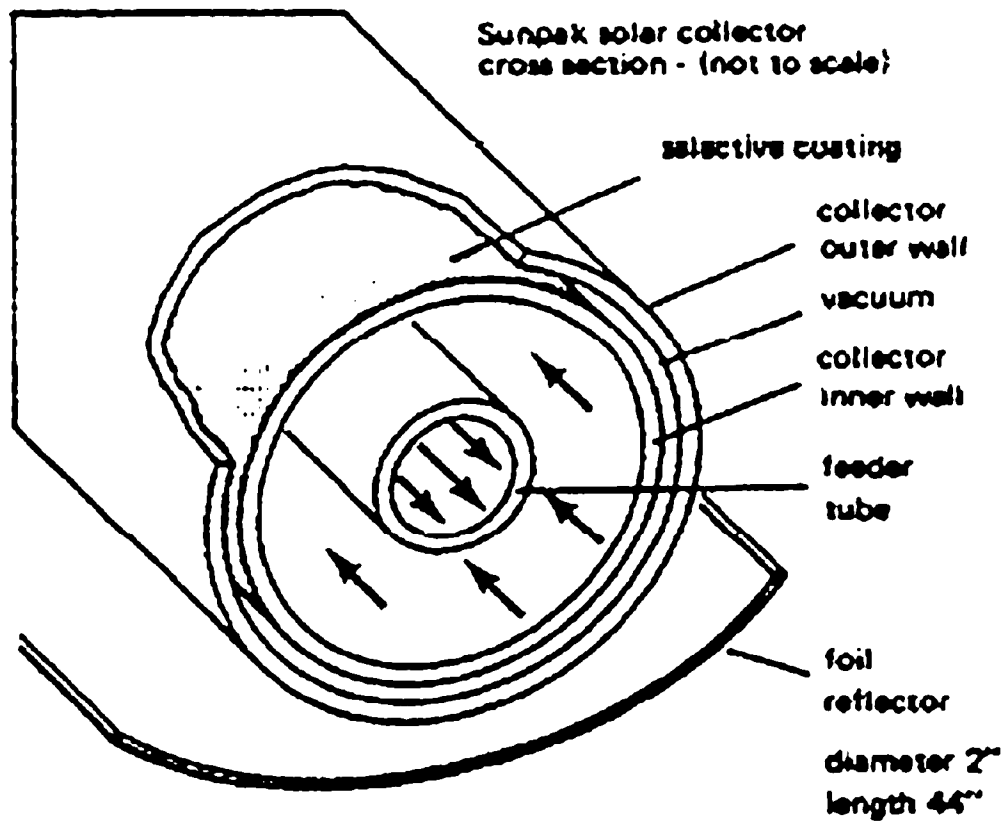

Figure 2-8

Evacuated tube solar heat collector.

**2.1.10 OTHER TYPES OF SOLAR COLLECTORS.** The three most common types of solar collectors are flat plate collectors, evacuated tube collectors, and concentrating collectors. Due to certain cost and performance advantages, flat plate collectors have been used extensively for residential DHW and space heating applications. Evacuated tube and concentrating collectors are used mostly in solar applications requiring very high temperatures. Some applications requiring large solar arrays are using evacuated and concentrating collectors. A brief description follows.

**2.1.10.1 EVACUATED-TUBE COLLECTORS.** Figure 2-8 shows an evacuated-tube collector. This type of collector uses a vacuum between the absorber and the

glass outer tube to significantly reduce convection and conduction heat losses. Evacuated-tube collectors operate essentially the same as flat-plate collectors. Solar radiation passes through the outer glass tube and is absorbed by the coated absorber. Heat energy is transferred to fluid flowing through the absorber. Most evacuated-tube designs collect both direct and diffuse radiation efficiently, but certain types are specifically designed for more efficient collection of direct radiation. Although evacuated-tube collectors are considerably more expensive than typical flat-plate collectors, they are much more efficient and more cost effective when high collection temperatures are needed for operating absorption chillers or for industrial process heating. They may not be as efficient as flat-plate collectors at low-temperature applications such as domestic water heating and space heating. For these applications, evacuated tube collectors should be judged on a cost per Btu basis to determine their effectiveness. Maintenance costs may be higher and heat dissipation coils may be required. Comparisons can be made using data similar to that in Figure 2-7 and Table 2-6, although evacuated tube collectors normally show a higher "all-day" performance than that indicated by the instantaneous values of Table 2-6.

**2.1.10.2 CONCENTRATING COLLECTORS.** Concentrating or focusing collectors intercept direct radiation over a large area and focus it onto a very small absorber area. These collectors can provide very high temperatures more efficiently than flat-plate collectors, since the absorption surface area is much smaller. However, diffuse sky radiation cannot be focused onto the absorber. Most concentrating collectors require mechanical equipment which constantly orients the collectors towards the sun and keeps the absorber at the point of focus. There are many types of concentrating collectors. The most popular types are the parabolic trough, the linear-trough fresnel lens, and the compound parabolic mirror. Figure 2-9(a) shows a linear concentrating or parabolic trough collector. It collects energy by reflecting direct solar radiation off a large curved mirror and onto a small absorber tube which contains a flowing heat transfer liquid. The absorber tube is encased in a glass or metal tube which may or may not be evacuated. This type of collector must track the sun and can collect only direct radiation. Figure 2-9(b) shows a linear-trough, fresnel lens collector. In this design a curved lens is used to focus incoming rays onto a small absorber plate or tube through which the heat

transfer liquid is circulated. This type of collector also requires a tracking mechanism and can collect only direct radiation. Figure 2-9(c) shows a compound parabolic mirror collector. The design of the mirrors allows the collector to collect and focus both direct and diffuse radiation without tracking the sun. Periodic changes in the tilt angle are the only adjustments necessary. Direct radiation is intercepted by only a portion of the mirror at a time, thus this collector does not collect as much solar energy as a focusing collector which tracks the sun. It is, however, less expensive to install and maintain. The absorber tube is encased within an evacuated tube to reduce heat losses. Many other types of concentrating collectors have been developed which produce high temperatures at good efficiencies. However, the potentially higher cost of installing and maintaining tracking collectors may limit their use in some applications. These points should be addressed early in project development when tracking collectors are considered. In addition, concentrating collectors must be used only in those locations where clear-sky direct radiation is abundant.

**2.2 ENERGY STORAGE AND AUXILIARY HEAT.** Since effective sunshine occurs only about 5 to 6 hours per day (in temperate latitudes), and since heating and hot water loads occur up to 24 hours a day, some type of energy storage system is needed when using solar energy. The design of the storage tank is an integral part of the total system design. Although numerous storage materials have been proposed, the most common are water for liquid collectors and rock for air. These have the advantages of low cost, ready availability and well known thermal properties. Precise heat storage sizing is not necessary, but economics and system design to determine the optimum range of sizes. The temperature range wherein useful heat is stored is important in determining optimum system size. If the volume of storage is too large, the temperature of the storage medium will not be high enough to provide useful heat to the building. Also, oversized storage requires excess floor space. If the storage is too small, the storage medium temperature will be too high, resulting in low collector efficiency. Practical experience in the industry as well as computer simulations and



experiments have resulted in general rules of thumb for storage sizing. These guidelines give storage sizes for which the performance and cost of active solar systems are optimized and relatively insensitive to changes within the range indicated. The optimum size of storage for active solar systems is 15 Btu/deg. F/ft<sup>2</sup> of collector area. The range is 10-20 Btu/deg. F/ft<sup>2</sup> (200-400 KJ/deg. C/m<sup>2</sup>). For water or air systems application of the rule gives the following.

- **WATER SYSTEMS.** Since water has a specific heat of 1 Btu/lb-deg. F, then 15 lb of water storage are needed per square foot of collector or considering the density of water, 8.33 lb/gal or 62.4 lb/ft<sup>3</sup>, then 1.8 gal of storage are needed for each square foot of collector (range 1.2 to 2.0 gal/ft<sup>2</sup>). The range in SI units is 50-100 liters/m<sup>2</sup>.
- **AIR SYSTEMS.** Since rock has a specific heat of 0.21 Btu/lb-deg. F, and rock densities (170 lb/ft<sup>3</sup>) typically contain 20%-40% voids, then the optimum storage size is 0.8 ft<sup>3</sup> per square foot of collector (range 0.5 to 1.15 ft<sup>3</sup> per square foot of collector). The range in SI units is 0.15 to 0.35 m<sup>3</sup>/m<sup>2</sup>.

In general, for equal storage capacity, the rock pebble bed would have to occupy a volume 2-1/2 to 3 times larger than a water tank. Rock storage bins have higher structural requirements, and tend to lose more heat due to their greater surface area. Rock bins generally provide good temperature stratification; contrary to practice in conventional DHW systems, stratification is desirable in both water and air solar systems. NCEL has done studies to show that good stratification can add 5%-10% to overall system performances. To achieve this, baffles or modified inlets to the tanks are used. However, specially designed tanks with baffles or diffusers are expensive and not readily available. To suppress convection warm water enters and leaves the top of the tank, and cold water, the bottom. In this way the hottest water goes to the load and the coldest to the collectors. A typical DHW system is shown in Figure 2-10. Use of two tanks insures that when hot water from the first (tempering) tank is available, the auxiliary heat will not come on; also less total fuel will be used to bring the smaller

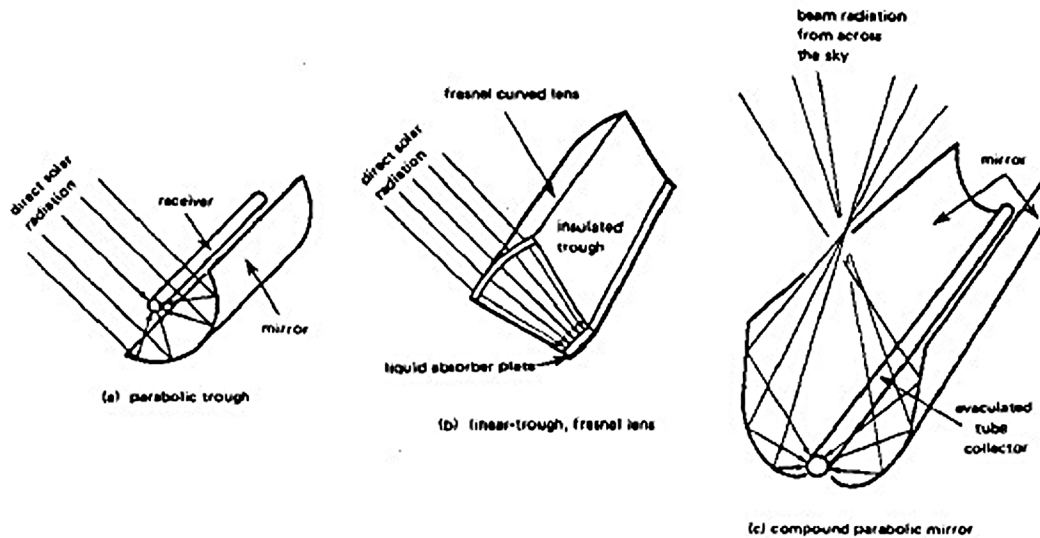

Figure 2-9  
Concentrating collectors for solar energy

second tank up to temperature. Single tank arrangements, while possible and economical, are not recommended due to the fact that they tend to activate the heating element every time there is a draw of water rather than wait for the solar collectors to provide additional heated water. Research is being done and new tanks designed to overcome this deficiency. The two-tank arrangement avoids this control problem. Two-tank arrangements are suited to retrofits since the second tank (the water heater) is already there. A variation would be to use a heat exchanger (copper coil) in the tempering tank collector loop for freeze protection. The tempering tank could then be an inexpensive unpressurized tank. Another method of heat storage in air systems that is currently being investigated is latent heat storage. Latent heat is stored in a material as it changes phase from a solid to a liquid. Materials which have melting points near the temperatures supplied by solar collectors store heat as they melt and release it as they resolidify. The two materials which have received the most attention are salt hydrates and paraffins. The advantage of latent heat storage is that it can store very large quantities of heat per pound of storage material. Therefore, less volume should be

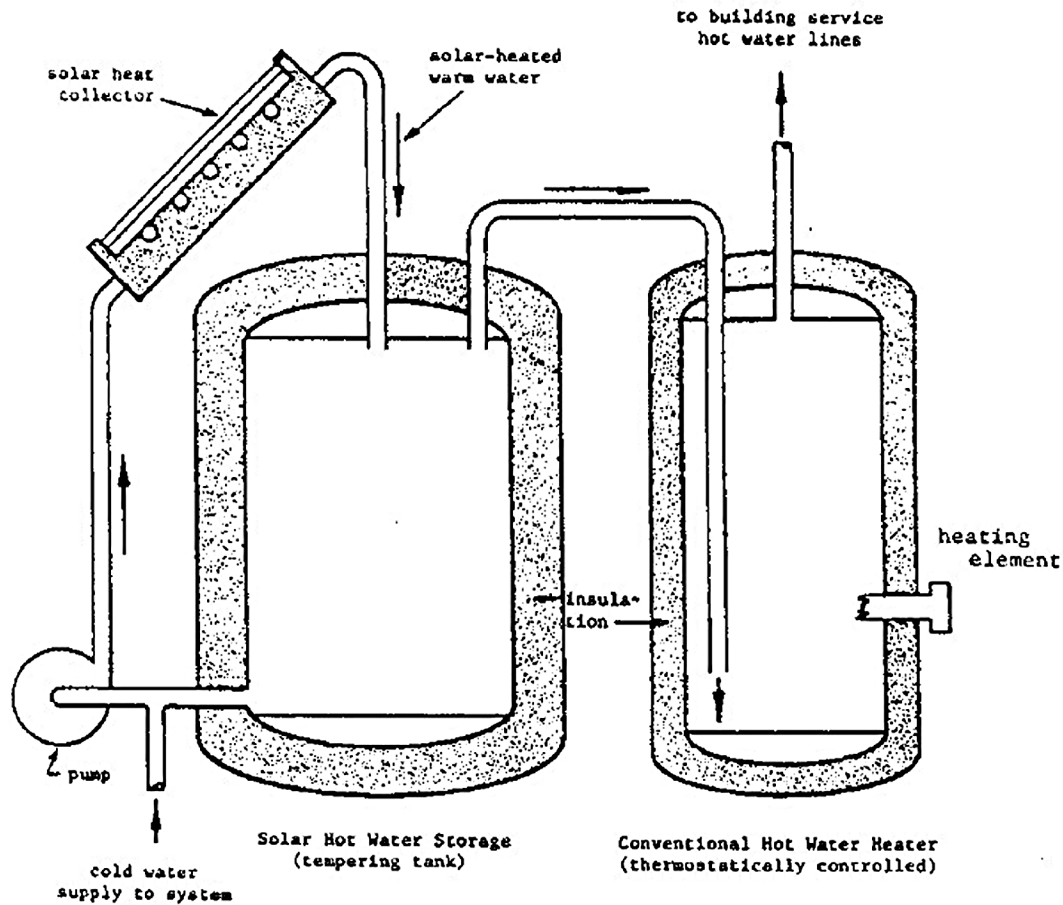

Figure 2-10

Schematic of potable hot water heating system using solar storage (tempering) tank ahead of conventional fueled or electric service water heater

required for latent heat storage than for heat storage in rock beds. However, problems of slow solidification and low heat conductivity retards effective heat transfer to and from the material. As a result, a large surface area-to-volume ratio is required, which significantly increases the effective volume of latent storage. solar storage (tempering) tank ahead of conventional fueled or electric service water heater.] Latent storage materials are often expensive when compared to rock. In addition, they must be packaged in individual containers to allow adequate heat transfer area. Many latent heat materials cannot withstand frequent recycling and must be replaced periodically. Research is being done by NCEL and others to develop practical latent heat materials

which can withstand extended recycling. NCEL is investigating a dissolved salt storage unit that uses immiscible liquids for the heat exchange surface which greatly reduces the problem of crystallization during recycling. Initial tests have been encouraging. Another major drawback of latent heat storage is that heat is stored at an average temperature with essentially no thermal stratification occurring in the storage unit. A high level of thermal stratification maximizes thermal performance because low temperature fluid can be delivered to the collectors and high temperature fluid can be delivered to the heat load. For example, the high degree of thermal stratification in rock-beds results in the delivery of 79 deg. F air to the collector and 120 deg. F to 150 deg. F air to the heat load. In comparison, latent heat storage in Glauber's salt occurs near an average temperature of 90 deg. F; thus air at 90 deg. F is delivered to both the collectors and the heat load. Due to the problems discussed, latent heat storage has not received widespread use. Since it is not economically justifiable to store huge quantities of heat, most solar systems cannot be depended on to provide 100% of the building's needs. Depending on the geographical area and size of the system, about 40% to 80% of the heat requirement is the average to design for. Therefore auxiliary heaters are necessary. They should be sized to provide all the energy requirements, although in some cases, again depending on location, it may be possible to increase storage volume and provide less than 100% backup auxiliary heat. This is especially true if the use of passive solar designs can be incorporated with active systems. The auxiliary heater should operate automatically as needed, use the most economical fuel, and share a common heat delivery system with the solar system. Often a heat pump is a good choice in that it can serve both as an auxiliary heater and work together with the solar system. In retrofit situations, the existing heater would be the choice.

**2.2.1 STORAGE TANKS.** Water may be stored in a variety of containers usually made of steel, concrete, plastics, fiberglass, or other suitable materials. Steel tanks are commercially available and have been used for water storage. They are available in many sizes and are relatively easy to install. However, steel tanks are susceptible to corrosion and should be lined or galvanized. Dissimilar metal at pipe connections should be separated by high temperature rubber connections or galvanic corrosion will

occur. Steel tanks must be well insulated to minimize heat losses. Concrete tanks are durable, but may be difficult to install. Concrete tanks cast in place, prefabricated septic tanks, or large diameter pipes may be used for water storage. A high temperature sealant or lining should be applied to the interior of the tank to prevent seepage of water through the tank. Although concrete is less conductive than steel, concrete tanks should also be insulated to reduce thermal losses. Leaks are difficult to repair. Fiberglass and plastic tanks are corrosion resistant and easily installed. They are available in many shapes and sizes. Although many commonly fabricated tanks will begin to soften at temperatures above 140 deg.-160 deg. F, there are more expensive, specially fabricated tanks available that can withstand temperatures up to 250 deg. F. The types of plastics needed to store large quantities of water at high temperatures can be more expensive than steel. When storage tanks are to be custom made, a calculation of heat loss against expected fuel cost inflation will almost always justify increasing insulation around the tank to R-19, 6 inches, compared with the usual 2 inches. HUD Intermediate Minimum Property Standards (U.S. Dept HUD, 1977) requires that tank losses be limited to 10% in 24 hours. Usually R-19 insulation will satisfy this requirement. It is a good practice to insulate tank supports from the ground if possible. Costs of storage tanks vary considerably depending on the quality of construction and the distributor. Table 2-7 summarizes advantages and disadvantages and Table 2-8 gives approximate comparative costs for tanks of various materials. All storage tanks for liquids should be located so that if they leak, damage to the building will be prevented. The cost of housing the tank or burying it must be included in the total cost of the solar heating system. Buried tanks must be protected from ground water, and buoyant forces resisted. Underground tanks are not preferred, if other options are available. Tanks must be reasonably accessible for repairs. In very mild or warm climates, outdoor location may be feasible. Tank connections should comply with local codes with regards to backflow preventers, safety relief valves, etc.

**2.3 DOMESTIC HOT WATER SYSTEMS (DHW).** Domestic hot water systems (DHW) (without space heating) may use lined, insulated, pressurized tanks similar to the conventional water heater. Appropriate temperature and pressure relief valves must be

used. Since it is possible for solar collectors to reach very hot temperatures, a tempering or mixing valve should be used. A typical two-tank installation with proper valves and connections would be as shown in Figure 2-11. To size the collectors and storage tank it is necessary to estimate or measure the hot water consumption of the facility or building. For typical family residences, 20 gal/day/person of hot water is normally consumed. If it is estimated the hot water consumption is larger than average, use 30 gal/day/person. So, 80 to 120 gal/day should serve a typical four-person family. Table 2-9 gives water consumption data for different types of conventional facilities and may be used to supplement over data.

#### **2.4 THERMOSYPHON, BATCH, AND INTEGRAL STORAGE COLLECTOR**

**SYSTEMS.** A variation of the DHW system is the thermosyphon system which uses the principle of natural convection of fluid between a collector and an elevated storage tank. As water is heated in the collector it rises naturally to the tank above. The bottom of the tank should be mounted about 2 feet higher than the highest point of the collector. This is the main disadvantage in that structural requirements will often prohibit the weight of a water tank on a high point of the structure. Also, since the thermosyphon system is connected directly to the potable water supply it is difficult to protect from freezing. However, new models are coming on the market that use Freon as the heat transfer fluid, solving the freezing problem. The advantages of thermosyphon units are that they do not require pumps or electronic control systems. Hence the costs to purchase and operate these components are eliminated. Also these systems save by virtue of eliminating these components as a source of reliability or maintenance problems. A last

Advantages			
Steel Tank	Fiberglass Tank	Concrete Tank	Wooden Tank With Liner
<p>Cost is moderate.</p> <p>Steel tanks can be designed to withstand pressure.</p> <p>Much field experience is available.</p> <p>Connections to plumbing are easy.</p> <p>Some steel tanks are designed specifically for solar energy storage.</p>	<p>Factory insulated tanks are available.</p> <p>Considerable field experience is available.</p> <p>Some tanks are designed specifically for solar energy storage.</p> <p>Fiberglass does not rust or corrode.</p>	<p>Cost is low.</p> <p>Concrete tanks may be cast in place or may be precast.</p>	<p>Cost is moderate.</p> <p>Indoor installation is easy.</p>
Disadvantages			
Steel Tank	Fiberglass Tank	Concrete Tank	Wooden Tank With Liner
<p>Complete tanks are difficult to install indoors.</p> <p>Steel tanks are subject to rust and corrosion.</p>	<p>Maximum temperature is limited even with special resins.</p> <p>Fiberglass tanks are relatively expensive.</p> <p>Complete tanks are difficult to install indoors.</p> <p>Underground installation not recommended.</p> <p>Fiberglass tanks must not be pressurized.</p>	<p>Careful design is required to avoid cracks and leaks.</p> <p>Concrete tanks must not be pressurized.</p> <p>Connections to plumbing are difficult to make leaktight.</p>	<p>Maximum temperature is limited.</p> <p>Wooden tanks must not be pressurized.</p> <p>Wooden tanks are not suitable for underground installation.</p>

Table 2-7

Advantages and disadvantages of tank types

Type of Installations	Cost Per Gallon for Tank Size (gal) -						
	80	120	300	500	1000	2000	4000
Steel, unlined, nonpressurized [b]			2.25	1.75	1.40	1.10	1.00
Steel, unlined, 120 psi [b]	4.00	3.50	2.50	2.40	2.10	2.00	2.00
Steel, glass lined, [b] 125 psi	6.00	5.50	5.50	--	--	--	--
.03-inch EPDM liner for unlined tank	1.10	1.00	0.90	0.80	0.70	0.60	0.40
Steel, stone lined, 125 psi	8.00	7.00	--				
Fiberglass tank, or polyethylene, nonpressurized	2.75	2.50	2.00	1.80	1.60	1.50	1.20
Concrete 6-inch insulation and sheath	3.00	2.80	2.40	2.20	2.00	1.60	1.40
Normal installation above ground including pad	1.50	1.50	1.50	1.40	1.30	1.00	0.75

[a] All prices, \$/gal, Oct 1983, Los Angeles area.

[b] Includes supports and fittings; add \$0.15/gal for phenolic lining of unlined tanks.

Table 2-8  
Storage Tank Costs

advantage is that they are completely independent of electrical grid power. Batch and integral storage collector (ISC) systems are similar in that they also do not have pumps or controllers. Batch systems (often called "breadbox" also) are simply a black painted storage tank (or several) installed in a weathertight box and glazed with glass or plastic. They depend on their heat transfer by flow of water through the system initiated whenever there is demand for water by the occupants. Integral storage collectors put the tank and collector together to form a large mass of fluid to be heated by the sun. The intent is to have a large enough mass of water that freezing will not be a problem except in the severest of climate. Surprisingly only about 30-40 gallons of water are needed to accomplish this over most of the United States. ISC systems also depend on system demand for their flow, but some models have also been configured to use the



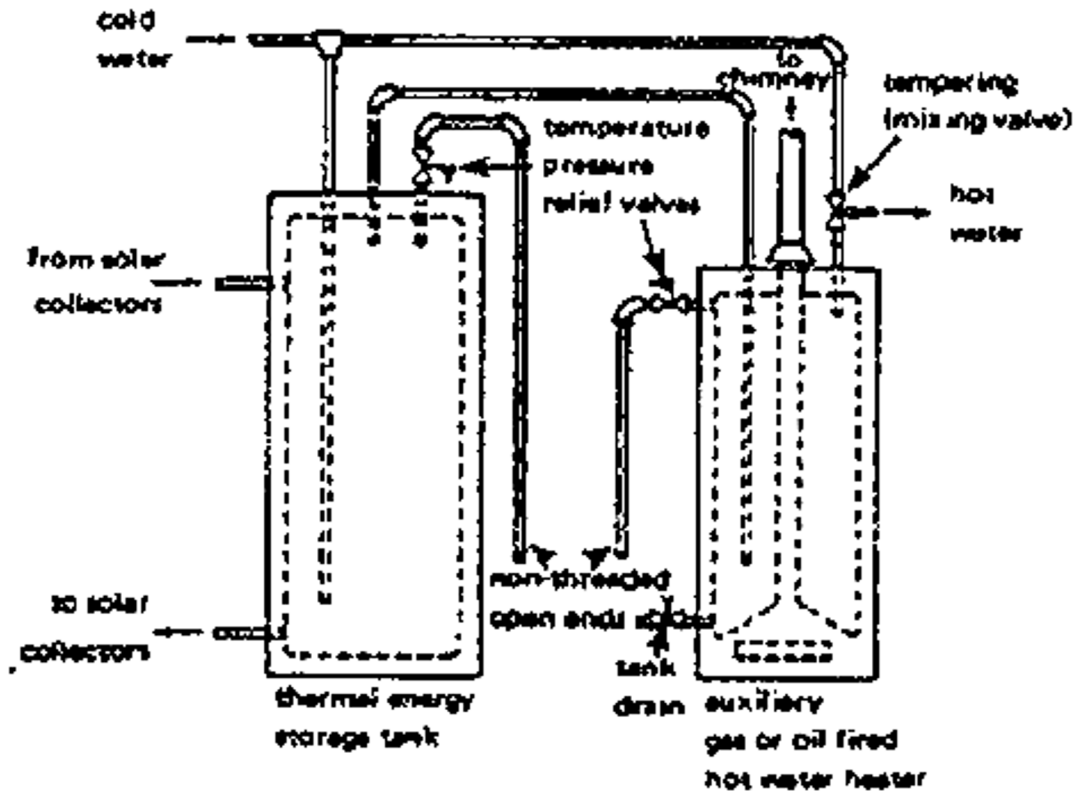

Figure 2-11  
Typical DHW Installations

thermosyphon principle. The testing of these units is different than regular solar collectors since the ASHRAE 93-77 standard does not apply. These units must be tested as "whole systems". The method is given in ASHRAE Standard 95-1981. At the time of this edition of the handbook much of this data is just becoming available. The trend seems to be that thermosyphon systems are probably the most efficient followed by ISC and batch systems in that order. NCEL has installed and tested a thermosyphon system and compared its performance to a pumped system that uses a differential (on/off) controller and one with a proportional (continuous) controller. As shown in figure 2-11a, the tank temperature rise for a one-day test was very similar for all three systems. Although the performance of the thermosyphon unit was very slightly lower it

Type of Building	Average Day
Men's Dormitories	13.1 gal/student
Women's Dormitories	12.3 gal/student
Motels (number of units):	
20 or Less	20.0 gal/unit
50	14.0 gal/unit
100 or More	10.0 gal/unit
Nursing Homes	18.4 gal/bed
Office Buildings	1.0 gal/person
Food Service Establishments	
Type A - Full meal restaurants and cafeterias	2.4 gal/average(a) meals/day
Type B - Drive-ins, grilles, luncheonettes, sandwich & snack shops	0.7 gal/average(a) meals/day
Apartment Houses (number of apartments):	
20 or Less	42.0 gal/apartment
50	40.0 gal/apartment
75	38.0 gal/apartment
100	37.0 gal/apartment
Over 130	35.0 gal/apartment
Elementary Schools	0.6 gal/student(a)
Junior & Senior High Schools	1.8 gal/student(a)

(a) Per day of operation.

Table 2-9

Hot Water Demands and Use for Various Types of Buildings

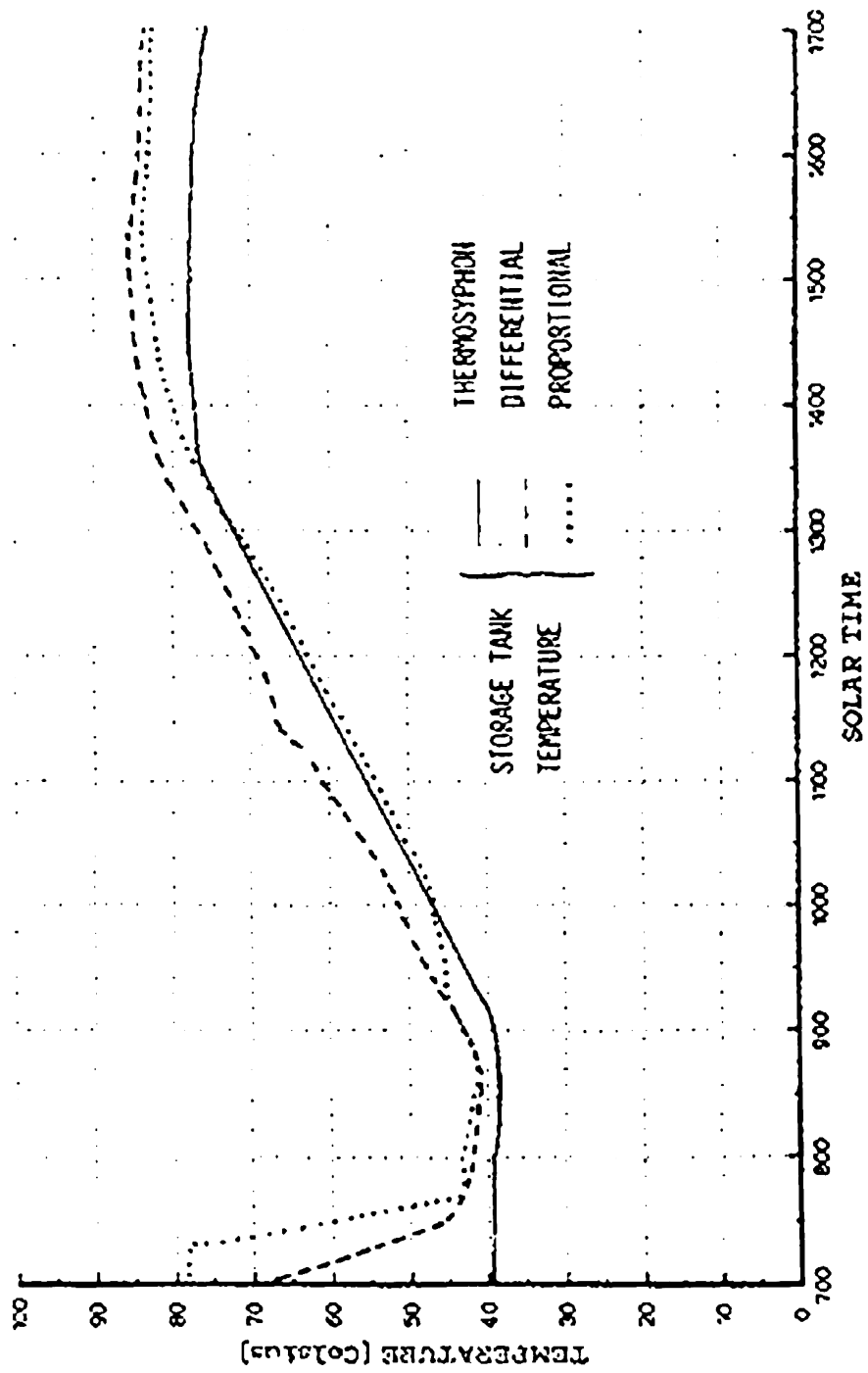

Figure 2-11a  
Thermosiphon System Tests

is not enough to rule out the use of these systems especially when their advantages of improved reliability and maintenance are considered. The important conclusion of these tests is that the performance is similar enough that the choice of which to use can be made by considering other pertinent factors of the installation. The results of system tests on these models are reported in the Directory of SRCC Ratings. Though slightly lower in performance, the inherent simplicity and implicit lower cost make these systems an attractive alternative. The user should insure that the freezing problem is adequately addressed should one of these models be used.

**2.5 SPACE HEATING AND DHW SYSTEMS.** Space heating systems are a simple extension of the DHW systems. The collectors and storage tank need to be resized to provide the greater loads. A heat delivery system is added and the auxiliary heater (or existing heater) is connected in as backup. The design of the space heating system, if a retrofit, will depend on the existing system. Water-to-air heat exchangers may be placed in existing ductwork, in which case, an unpressurized, unlined tank may be used and represents a minimum heating system as in Figure 2-12. To provide corrosion and/or freeze protection the use of a closed collector loop and heat exchanger are required as in Figure 2-13. The cautions given in Figure 2-5 regarding toxic heat transfer fluids must be observed. The most versatile system would be as shown in Figure 2-14 in which space heating and DHW are provided. Remember that 100% backup capability is needed but that oversizing is not necessary. Auxiliary heat can be used directly such as a heat pump or separate furnace or it could be added to the main storage tank using a heat pump, a separate boiler, or electrical resistance heating. DHW could be added to Figure 2-12 and 2-13 by adding a preheat coil in the storage tank. Figure 2-12 has the potential to provide some building cooling by using the collector at night to radiate heat to the sky and storing cool water for use during the day. Or a heat pump could be used to cool the building, reject heat to the storage tank during the day, and then, as before, cool the tank at night through the solar collectors. Unglazed collectors are superior to glazed collectors for this application. There are many variations that could be used with the configurations given in Figures 2-12 through 2-14. Air type space heating systems are sometimes used and a typical system is shown in Figure 2-15 (see Table 2-1 for

advantages of air versus liquid). The heat storage tank is replaced by a rock bed (nominally 1-3 inch diameter). Rock provides very desirable temperature stratification. Designs should emphasize minimum pressure drop through the rock bed. The rocks carefully washed and placed can be stored in a bin, which should be insulated, or beneath the building if this is feasible. Keep dust to a minimum. Heat collected by the collectors is blown through the rock bed from top to bottom. Heat is delivered from storage to the building by circulating air in the reverse direction, bottom to top. Note that in contrast to water storage, heat cannot be added to and removed from the rocks at the same time. Hollow core concrete wall panels and decks have been used for solar heat storage and air ducts. They provide thermal mass and air flow passages in one design. Attention to proper sealing is necessary to prevent dust contamination. During heat collection, the rocks at the top of the bin will attain a temperature nearly equal to that of the incoming solar heated air, while the air leaving the storage will be delivered to the collectors at the minimum temperature of the rocks. The conduction between the rocks is small, thus with no air circulation the rock bed will remain stratified with the top of the rock bed warmer than the bottom. Also, limited conduction and convection in the rock-bed significantly reduces heat loss from the rock-bed. Heat is drawn from the storage by circulating building air directly through the rock bed from bottom to top. The air will then be delivered to the building at a temperature near the maximum temperature of the collectors. If additional heat is required, supplementary heat is added down-stream from the storage unit. This system allows the rock bed to deliver useful heat until all of the rocks are at room temperature. A variation is a no-storage air heating system which circulates heated air when available. Performance is limited to daytime heating due to the lack of storage, but such systems are well suited to warehouses and factories which have mainly daytime operations. DHW is provided in Figure 2-15 by pumping the water in the preheat tank through an air-to-water heat exchanger placed in the return air duct from the collectors. This is not very efficient and is one of the disadvantages of the air system. It would, perhaps, be just as cost effective to have a separate small liquid system (say two collectors) to provide DHW. Both air and liquid space heating systems require a heat delivery network to transfer heat from storage to the building. Most of the buildings in the United States are heated by circulation of warm air through the building.

The air is usually heated in a central location and ducted to the individual rooms. This method is used particularly in residential buildings. Hydronic heating is another common heat distribution method. In hydronic heating systems hot water or steam is circulated through pipes to "convectors" located in the individual rooms of a building. Modern hot water convectors are comprised of one or more finned tubes located on the wall near the floor. These baseboard heaters deliver heat to the room mainly by convection as air moves through the fins. A less common heating system consists of lengths of tubing embedded in the floors, walls, or ceilings of the living space. Warm water is supplied to the tubes by a boiler and the heat is transferred to the room by convection and radiation.

**2.5.1 HEAT DISTRIBUTION FOR LIQUID-TYPE SOLAR SYSTEMS.** The temperature requirements of a hydronic heating system are dependent on the amount of heat exchanger surface. Most baseboard heaters have comparatively small surface areas, so they require higher temperatures, typically about 180 deg, F. If larger heat transfer areas are available as in older or modified hot water systems, temperatures of 120 deg. F may be sufficient. Temperatures of 100 deg. F are adequate for the system which uses entire floors, walls, and ceilings as radiator surfaces. During the winter, typical liquid-type solar systems are seldom operated at delivery temperatures above 150 deg. F. Thus it is evident that the use of solar heated water in standard baseboard heaters is impractical. Only modified baseboard heaters of adequate size or radiant panels are suitable for use in hydronic systems which use solar heated water. One of the most economical means of auxiliary heat supply and heat distribution for liquid-type solar systems involves the use of a warm air system. A typical system is illustrated in Figure 2-16. In this system the warm air furnace is located downstream from a liquid-to-air heat exchanger which is supplied with solar-heated water. The furnace can then serve to boost air temperature when insufficient heat is available from the solar heated water, or it can meet the full heat load if no heat is available in solar storage. Auxiliary heat can be supplied by a gas, oil, or electric furnace, or by the condenser of an air-to-air heat pump. Another method of heat distribution involves the use of a water-to-air heat pump

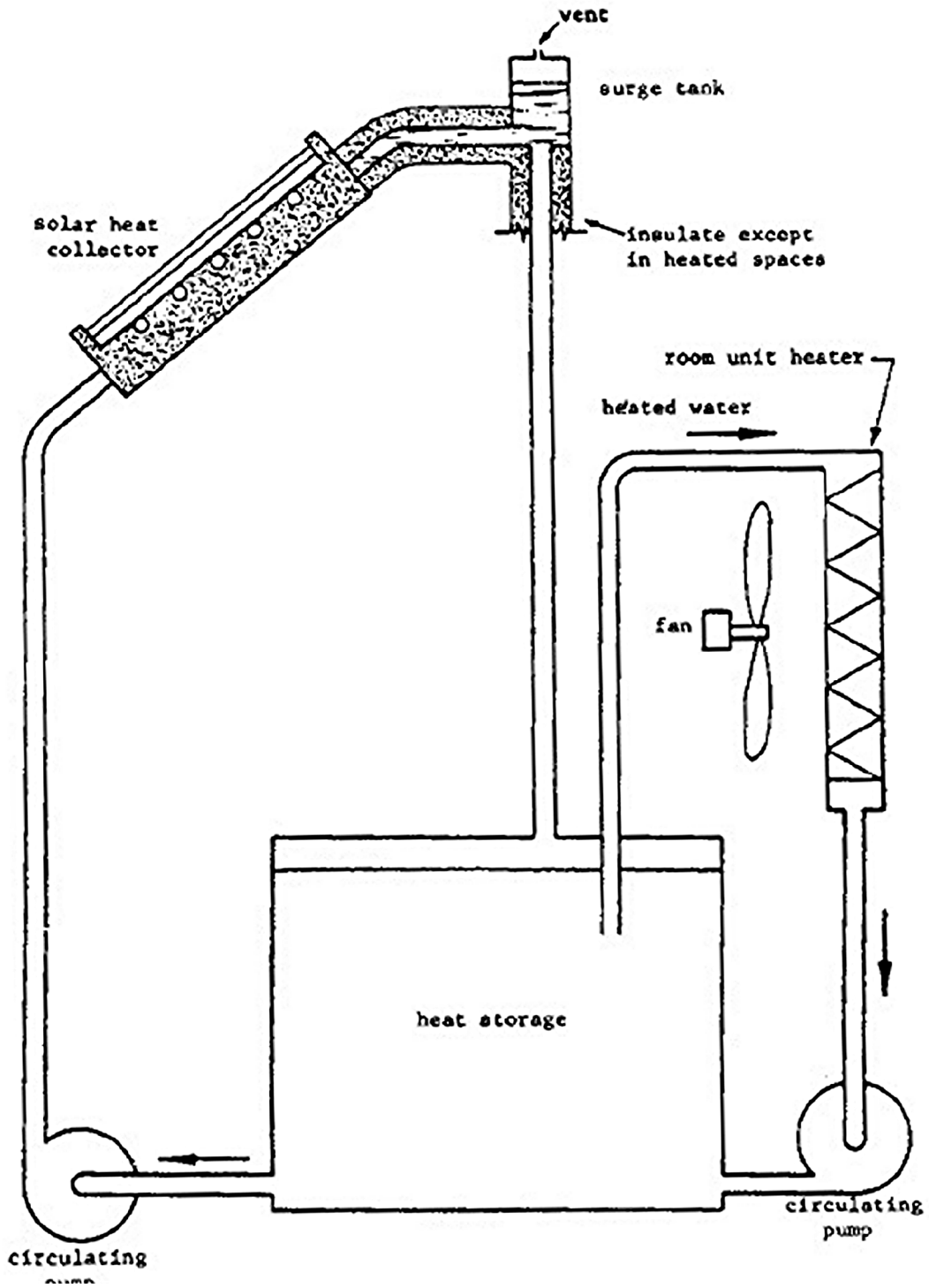

Figure 2-12  
 Minimum heating system, showing relationship of  
 collector, storage, and room unit heater

which draws heat from the solar storage tank and pumps it to a condenser coil which is placed in a central air duct. The advantage of this system is that it can effectively use heat from solar storage at temperatures down to 45 deg. F, thus more of the stored heat is available. Also, average storage temperatures are lower, resulting in significantly increased collector efficiency.

**2.5.2 HEAT DISTRIBUTION FOR AIR-TYPE SOLAR SYSTEMS.** The pipes and pumps of the liquid-type system are replaced by air ducts and fans. The warm air system is obviously the best heat distribution system for use with an air-type solar system. The ability to circulate building air directly through the collectors is one of the major advantages of an air-type solar system. The rock bed storage also works best with a warm air system. Although warm air as low as 100 deg. F can be used to heat an occupied building, most existing warm air systems are sized assuming warm air temperatures of 120 deg. F to 150 deg. F. Typical mid-day collection temperatures usually range from 130 deg. F to 170 deg. F. Maximum storage temperatures are typically around 140 deg. F at the end of the collection period. Thus the heating load can be met by the temperature of the solar heated air a large portion of the day. When storage temperatures are insufficient to maintain the desired temperature in the building, heat from an auxiliary source must be added to supplement the solar heated air. The auxiliary furnace is located downstream from the rock bed so that the rock bed serves as a pre-heater for the furnace. This arrangement allows the rock bed to deliver useful heat until all of the rocks are at room temperature. An air handler unit provides the dampers and blowers necessary to direct air circulation between the solar collectors, rock-bed, and building as needed. An air handler unit may be more expensive than the combined cost of individual dampers and blowers, but it will probably be less expensive to install. It is also more compact.

**2.5.3 HEAT PUMPS.** Heat pumps have been mentioned in previous sections as a possible choice for auxiliary heaters. Some manufacturers are combining solar systems with heat pumps for the purpose of reducing auxiliary energy costs. When a heat pump and a solar system are combined in this manner, the system is usually called solar



assisted or solar augmented heat pump (SAHP) system. Solar assisted heat pump systems can be configured in many different ways. For example, the solar collectors can be either water or air types, the heat storage medium can be water or a solid material such as rock or brick, and the heat pump can be of either the air-to-air design or the water-to-air design. But heat pumps have a characteristic which can limit their effectiveness: the efficiency and capacity of a heat pump decreases as the temperature of the heat source (usually outdoor air) decreases. This deficiency can be overcome, however, by using solar collectors to gather the sun's energy for the purpose of keeping the heat source in the temperature range required for efficient heat pump operation.

**2.5.3.1 AIR-TO-AIR HEAT PUMPS.** Some air-to-air heat pumps function very well as an auxiliary heater at temperatures down to 20 deg. F. Below these temperatures, they suffer in efficiency and performance. When solar assisted by heat from a rock-pebble storage bed and air collectors, the heat pump adds much to the performance of the solar energy system. Without such a solar assist, air-to-air heat pumps have limited utility in cold climates. Their use should be carefully checked with the local utility and pump manufacturer. The heat pump also provides cooling during the summer. It thus has year-round utility. Heat pumps should be comparison-shopped. The purchaser should look at the cost, performance, service, and expected life. Units differ considerably from manufacturer to manufacturer.

**2.5.3.2 LIQUID-TO-AIR HEAT PUMPS.** The liquid-to-air heat pump is an ideal auxiliary heater when coupled with liquid solar storage. It operates at very low cost. And it greatly enhances solar energy collection by drawing down the temperature of the solar storage water to as low as 45 deg. F. It should be considered for all installations, except those with existing fossil fuel furnaces and no need for summer cooling. Out of the many SAHP configurations which could be used, the two most in use are called the "series" and "parallel" configurations. Figure 2-17 is a series SAHP system. When the system is used for heating, water from the storage tank is circulated through water-cooled collectors where it is heated before returning to the storage tank. Warm water from the storage tank is also circulated through a water-to-air heat pump. Heat is removed from the water and transported to the indoor air by the heat pump and the water returns to the storage tank at a lower temperature. If heat is added to the water in

the tank faster than it is removed by the heat pump, the temperature of the water will rise. When the water temperature is high enough (about 104 deg. F), heat can be extracted directly from the water by means of water-to-air heat exchanger. In this mode of operation, the heat pump is shut off. Auxiliary electrical resistance heaters are provided to make up the balance of the heat load if the heat from the heat pump or water air heat exchanger is not sufficient to meet the demand. Normally this could be "off-peak" power for the auxiliary heater. When used for cooling, the heat pump transports heat from the building to the water in the storage tank thereby causing the temperature of the water in the tank to rise. During spring and fall, when it is not unusual to have a light cooling load during the day and a light heating load at night, the heat in the storage system is simply shuttled from the building to storage during the day and from storage to the building at night, and the solar collectors are used only to make up for lost heat. During periods of prolonged cooling demand, the heat pumped into the storage tank might be sufficient to cause the temperature of the water to rise to where the heat pump will no longer operate. Thus, provision must be made for rejecting excess heat. One method is to add a cooling tower to the system to cool the water. Another method is to circulate water through the solar collectors at night and reject heat by radiation to the night sky. During periods of high cooling load it is not desirable to also add heat to the storage tank by circulating water through the solar collectors. Therefore, when the system is in the cooling mode the solar collector circuit can be used to heat DHW. The "parallel" SAHP system is shown in Figure 2-18. The solar heating system and the heat pump operate in parallel. Solar heat is used directly rather than being transferred to a storage medium and then transported into the building with a heat pump. This system is essentially a direct solar heating system with an air-to-air heat pump as a backup heating system. The choice of a "best" system is difficult to make due to the many variables involved. For example, in addition to the two configurations shown in Figures 2-17 and 2-18, one could examine a series system with low cost (unglazed) collectors, or a series system with air-collectors and rock storage, or a parallel system with low cost collectors, etc. Each system would be highly dependent on geographical location, type of construction, etc. One such analysis done at NCEL comparing several systems to a standalone air source heat pump, showed the "parallel"

system to have the best comparative performance. Each heat pump configuration should be considered on a case-by-case basis. The analysis of these systems is beyond the scope of the worksheets given in this course, and the reader is directed to more sophisticated computer programs.

**2.6 PASSIVE SYSTEMS.** NCEL has published a contract report, "Passive Solar Design Procedures for Naval Installations" that is a reference on this subject. It contains data and worksheets to size passive solar designs at 200 geographical locations. Over 100 different passive designs can be considered and the method is applicable for single family residences, family townhouses, dormitories (i.e. BEQ's), small offices, and other concrete block buildings. A "passive" solar energy system is one which uses the building structure as a collector, storage and transfer mechanism with a minimum amount of mechanical equipment. Some would include a thermosyphon, batch, and ISC systems in this definition. As a rule, passive systems are generally difficult to retrofit. Another disadvantage is that the owner or occupant may be required to perform daily tasks, such as covering a south facing window at night, opening and closing shutters, etc. Although the specific arrangements vary, all of these systems rely on direct solar heating of storage. The storage then heats the house. A few examples are shown in Figure 2-19. Given the solar gain available on a vertical surface, the simplest and most obvious means of solar heating is just to let the sun shine in through large, south-facing windows. In fact, in a house with any south-facing windows, that is what is already happening to some degree. But the sunshine through the windows seldom heats the whole house. There are two reasons for this. First, most houses do not have enough south-facing glass. Second, houses lack enough storage to soak up the heat and keep it until night. Even rooms that overheat during the day cool off all too rapidly in the evening. On many buildings it is possible to add south-facing windows or skylights to increase direct solar heating. However, the extra window area can cause a "fry or freeze" situation unless storage and night window insulation is added as well. There must also be provisions for getting heat from the rooms receiving sunlight to the rest of the house. Providing such storage and delivery of solar heat gained through windows is

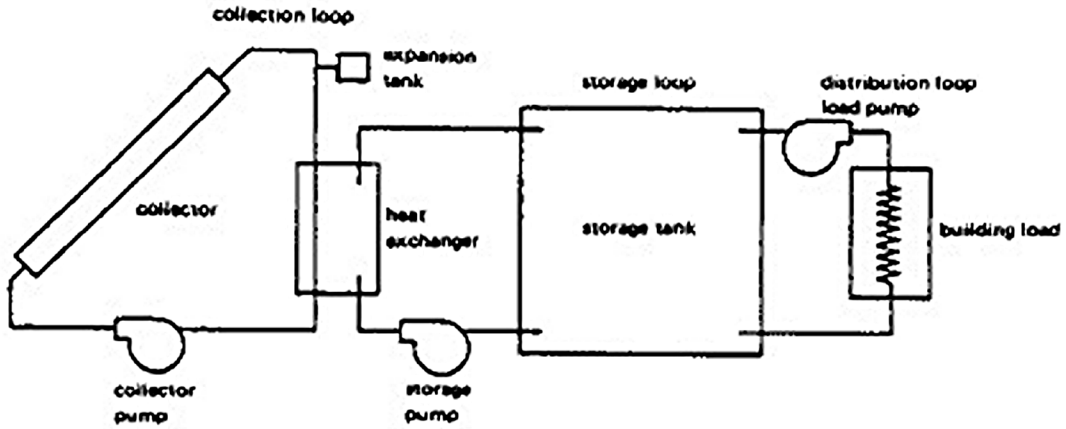

Figure 2-13

Space heating system with closed collector loop

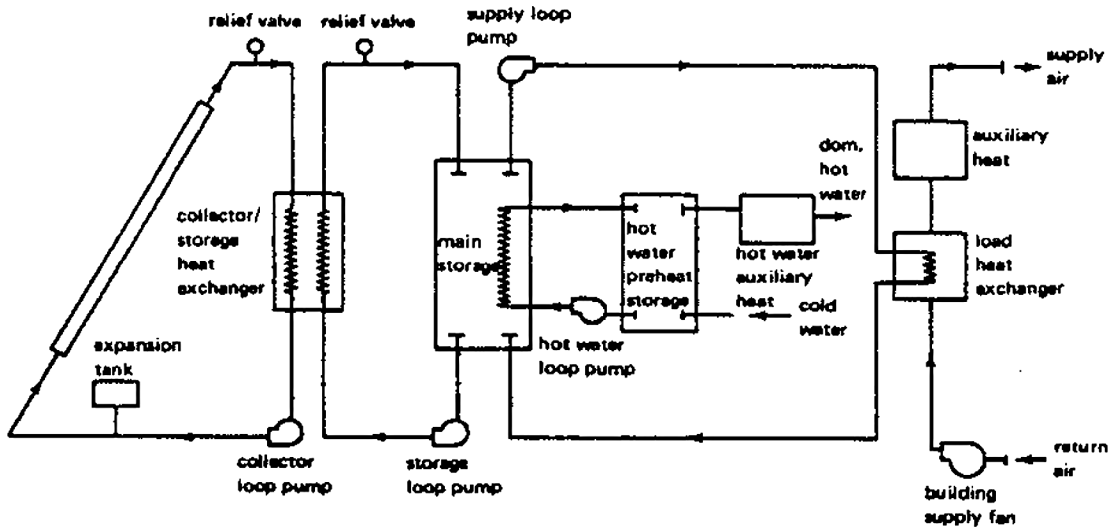

Figure 2-14

Space heating and domestic water system

the basis of passive solar heating systems. As shown in Figure 2-19 the type of storage used and where it is located with respect to the windows varies for different passive systems. Tall metal or fiberglass tubes can be used to hold water instead of drums. Entire walls of solid concrete or grout-filled masonry store solar heat well. Slab floors can absorb solar heat coming in through windows, skylights, or greenhouse glass. In each of these systems, the sunlight coming in through the glass must shine directly on the storage. If it does not the storage cannot absorb enough solar heat to provide much warmth for the house. Most passive systems deliver heat to the rest of the house "naturally" - that is, the heat moves by itself without use of pumps or fans. There is some natural regulation of how fast heat moves from the storage into the house - the colder the house gets, the faster the heat is drawn out of the storage. That is how the drum wall works. In other passive systems, solar heat is "trapped" between the glass and storage (in the air space between the glass and a concrete wall, or in an entire greenhouse), and the amount of heat allowed into the house is controlled by opening and closing vents, either manually or automatically. The performance of passive systems depends not just on how much solar heat they can collect, but also on how much of that heat is lost through the glass at night. The most common solution to the problem of heat loss is to install movable insulation (such as insulating curtains) between the glass and the storage. The curtains or other devices are moved during the day to let the sunshine in, and closed at night to reduce heat loss. Certain conditions must be present to do a simple passive retrofit. Since the basis for passive heating is to "let the sun shine in," the building must have extensive south-facing windows or skylights or places where they can be added. In addition, there must be a place close to the windows where storage can be located. The storage must receive midday sun. The problem here is that drums of water and masonry walls are so heavy that most existing floors can't support them. If the floor is not strong enough, there are at least two possible alternatives. One is to put the water or masonry wall on its own foundation on the exterior of the south wall. Another is the technique of turning a room addition into a solar heater that provides warmth for the rest of the house as well. As with active solar systems and heat pumps, there are endless variations of the passive technique, limited only by one's imagination. There are systems that use water on the roof to absorb heat

directly, and there are clever ways to insulate glass at night by blowing Styrofoam beads between two glass panes (BEADWALL of Steve Baer). Also natural objects such as earth berms to protect from winds and trees which shade in summer and let light pass in winter should be considered. Figures 2-20 through 2-23 show various representations of some of these passive techniques used either by itself or in conjunction with air collectors and thermosyphon systems. Although passive systems are rather simple in construction and design, their performance analysis is often complicated by a vast interplay of many components. Here are some "rules of thumb" that should be useful for passive designs:

- South-facing passive storage walls in direct sunlight should have a minimum of 30-lb water storage or 150-lb masonry (concrete) storage per square foot of south vertical glazing. If the storage media is not located in direct sunlight, four times this amount will be needed. At least 5-6 gallons water storage (about 45 lb) per square foot of south glass is recommended.
- Shading of south windows should be used to reduce summer and fall overheating. One effective geometry is a roof overhang which will just shade the top of the window at noon (solar time) sun elevation of 45 deg. and will fully shade the window at noon sun elevation of 78 deg. F.
- The best thickness of a Trombe wall is from 12 to 16 inches. The masonry should have a high density - at least 100 lb/ft<sup>3</sup>. Thermocirculation vents can be used to increase daytime heating but will not increase nighttime minimums. Vents should have lightweight passive backdraft dampers or other means of preventing reverse flow at night.
- Two to three square feet of south-facing double glazing should be used for each Btu/deg. F-hr of additional thermal load (i.e., exclusive of the glazing). This will give 70% to 80% solar heating in northern New Mexico (Los Alamos) for a building kept within the range of 65 deg. F to 75 deg. F.
- An easier to use rule is that for a well-insulated space in 40 deg. N latitude in cold climates (outdoor temperature = 20 deg. F to 30 deg. F) the ratio of south glazing to floor area is in range 0.20 to 0.25 to maintain an average space temperature of 68 deg. F over 24 hours (e.g., a 200 ft<sup>2</sup> floor space needs 40-50

ft<sup>2</sup> of south glazing). In temperate climates (35 deg. F to 45 deg. F outdoor temperature) use ratios in the range 0.11-0.17.

- For greenhouses: To determine solar gain:  $S = 1200 \text{ Btu/ft}^2$  of glazing per clear day,  $S = 700 \text{ Btu/ft}^2$  per average day. Double glaze only south wall. Insulate all opaque surfaces to R20, outside foundation to frost line to R10, minimize infiltration with caulking. Thermal mass = 5 gal of water or 1-2/3 ft<sup>3</sup> of gravel per square foot of glazing. If storage is thermally isolated from greenhouse, air should be moved at 10 ft<sup>3</sup>/min per square foot of glazing through the storage.

**2.7 SOLAR COOLING SYSTEMS.** The state-of-the-art of solar cooling has concentrated primarily on the developmental stages of systems in the last few years. Various methods have been researched, and some demonstrated, but only a few systems have been installed for other than research purposes. Solar cooling systems are attractive because cooling is most needed when solar energy is most available. If solar cooling, can be combined with solar heating, the solar system can be more fully utilized and the economic benefits should increase. Solar cooling systems by themselves, however, are usually not economical at present fuel costs. Combining solar heating and cooling systems is not easy because of the different system requirements. This can best be understood by summarizing the different solar cooling techniques. As with solar heating, the techniques for solar cooling consist of passive systems and active systems. The passive systems use some of the techniques discussed above. For active solar cooling systems the three most promising approaches are the heat actuated absorption machines, the Rankine cycle heat engine, and the desiccant dehumidification systems. A brief summary of these systems is given here.

**2.7.1 ABSORPTION COOLING.** Absorption cooling is the most commonly used method of solar cooling. An absorption refrigeration machine is basically a vapor-compression machine that accomplishes cooling by expansion of a liquid refrigerant under reduced pressure and temperature, similar in principle to an ordinary electrically operated vapor-compression air conditioner. Two refrigerant combinations have been used: lithium

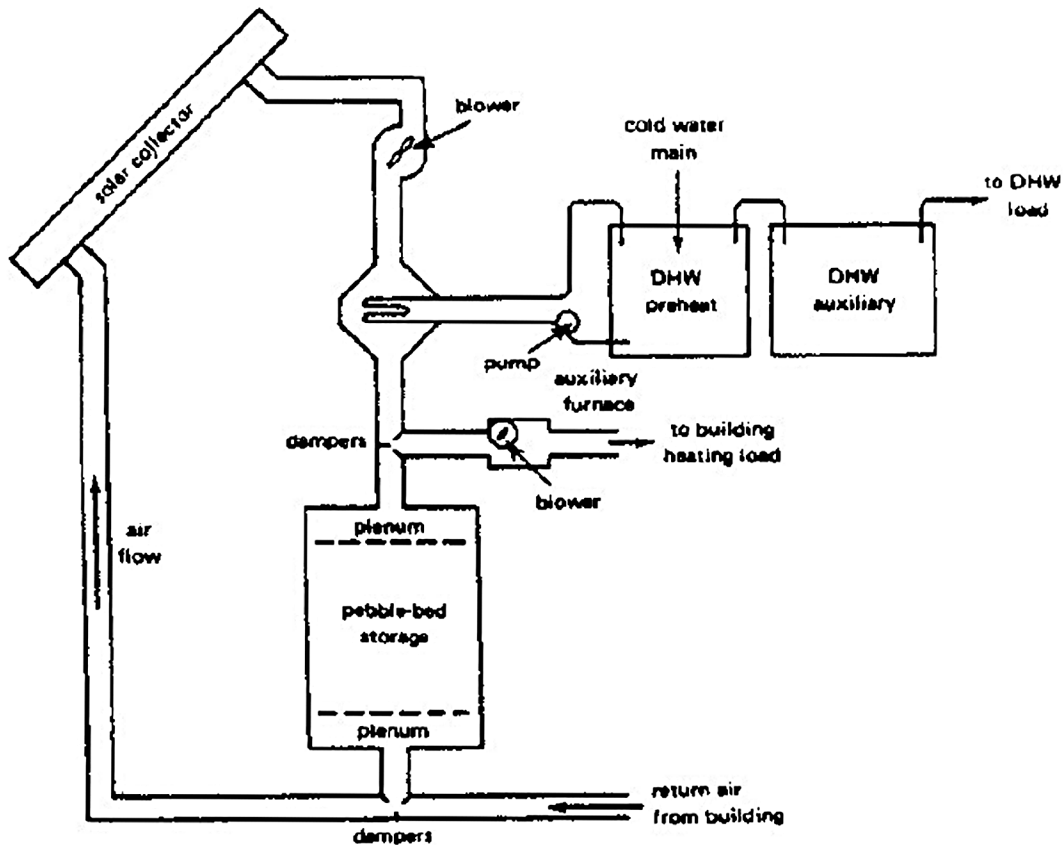

Figure 2-15

Typical air-type space heating system

bromide and water, and ammonia and water. There have been a number of proposed solid material absorption systems also. Figure 2-24 shows a typical lithium bromide (LiBr) absorption cooler. In the absorption cooler, heat is supplied to the generator in which a refrigerant is driven from a strong solution. The refrigerant is cooled in the condenser and allowed to expand through the throttling valve. The cooled, expanded refrigerant receives heat in the evaporator to provide the desired cooling, after which the refrigerant is reabsorbed into the cool, weak solution in the absorber. The pressure of the resulting strong solution is increased by pumping and the solution is available to repeat the process. The performance of the system is governed largely by the temperature difference between the generator and the condenser and absorber units.



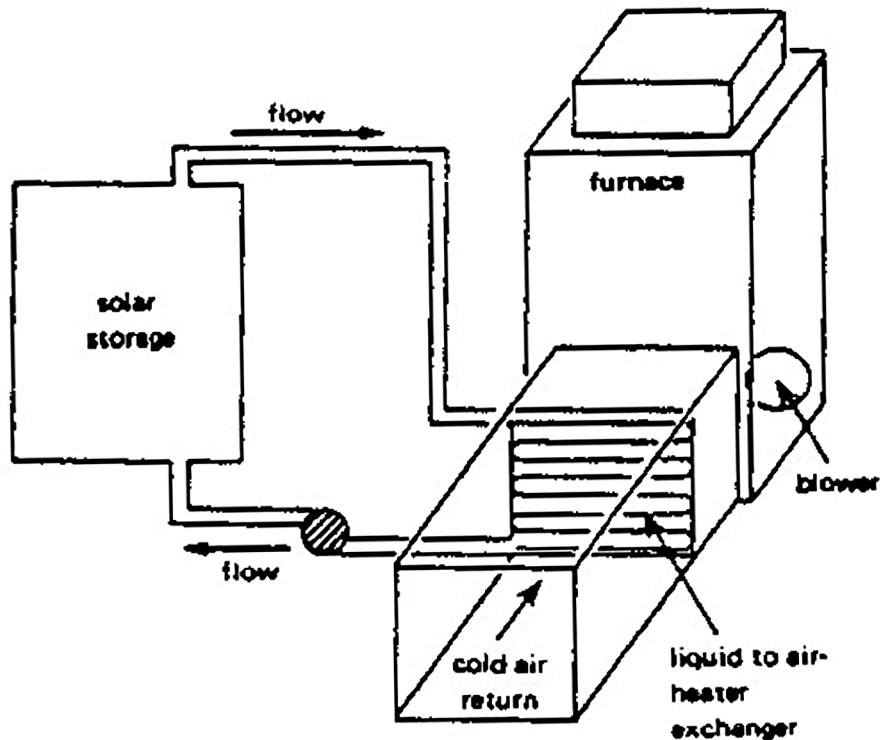

Figure 2-16

A liquid-to-air heat delivery system

Since the generator temperatures in solar driven systems are only moderate, it is important to keep the condenser and absorber temperatures as low as possible. The LiBr system is preferred over ammonia systems for solar energy applications because of the lower generator temperatures required. Permissible generator temperatures for a water-cooled LiBr system range from 170 deg. F to 210 deg. F (76 deg. C-99 deg. C) compared to the 205 deg. F to 248 deg. F (95 deg. C-120 deg. C) temperatures required for a water-cooled ammonia absorption system. Most, if not all, of the commercially available absorption units use LiBr and water as the absorbent-refrigerant fluid pair. Because the LiBr will crystallize at the higher absorber temperatures associated with air cooling, these units must be water cooled. A prototype ammonia-water unit, amenable to direct air cooling, has been built by Lawrence Berkeley Laboratories. A number of equipment requirements and limitations must be considered

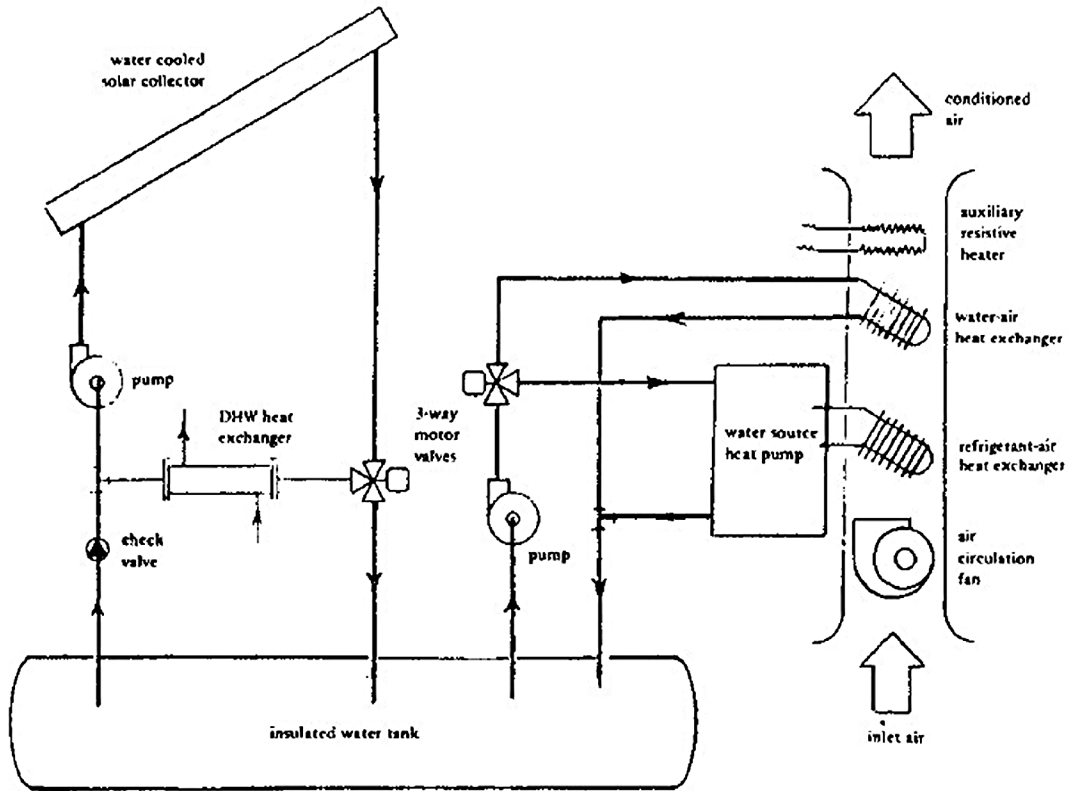

Figure 2-17  
Series-connected, solar-assisted heat pump system

in the analysis and design of solar powered absorption systems. The first consideration involves the type of collector used. The temperatures required by absorption coolers are obtainable with flat plate collectors but at low collection efficiencies. Collection efficiency is improved with an increased number of glazings and with a selective surface, therefore, it may be cost effective to improve the collector rather than to simply oversize. Concentrating or evacuated tube collectors are usually used in these applications. If concentrating collectors are used, the associated higher costs and potentially increased maintenance for the tracking mechanism must be considered. In general, concentrating collectors operate at higher efficiency at these higher temperatures. However, the higher temperatures are usually not required to operate the space heating system.

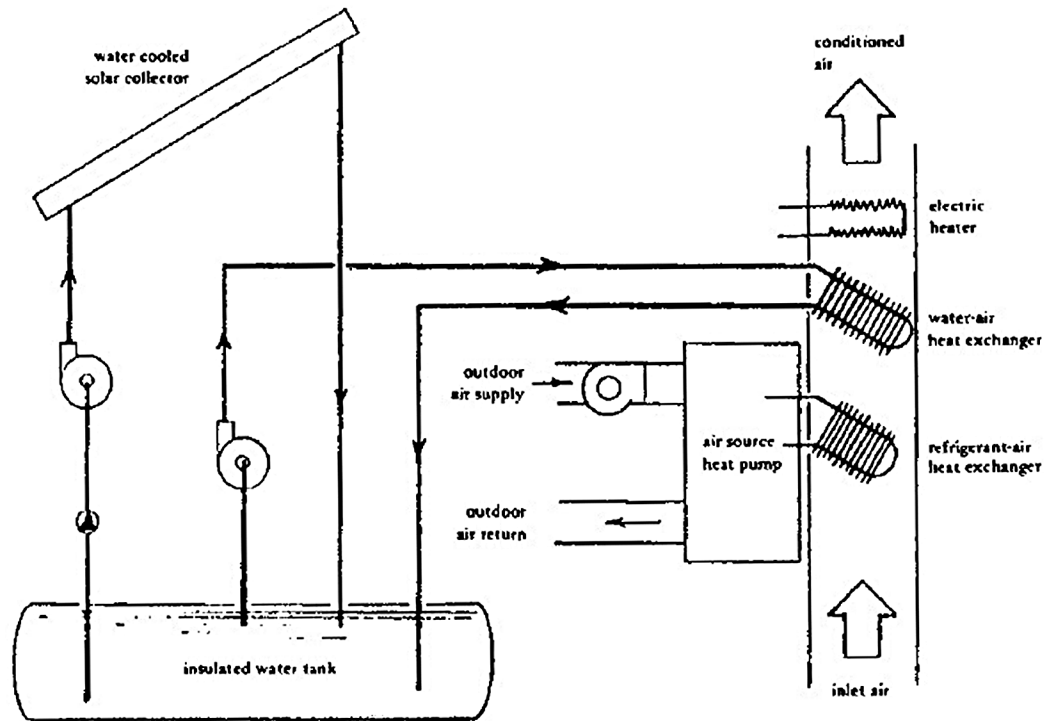

Figure 2-18

Series-connected, solar-assisted heat pump system

Therefore, the relative importance of the two thermal loads must be considered when selecting a system. The second consideration involves the means of delivery of the heated fluid to the absorption cooler. Since, in many climates, the cooling load is simultaneous with and often proportional to the solar insolation, it may be desirable to allow the heated collector fluid to bypass the storage unit. Other climates may require a hot storage unit but one of considerably smaller size than the one used for heating purposes. The important requirement is that high temperatures be available during periods of heavy cooling load. A third consideration deals with the problem of reduced efficiency of the absorption cooler under start up and transient conditions. Typical absorption coolers do not reach operating efficiency until after an hour or more of operation time. A machine which is cycled on and off regularly will have a drastically reduced average coefficient of performance when compared to a machine in steady

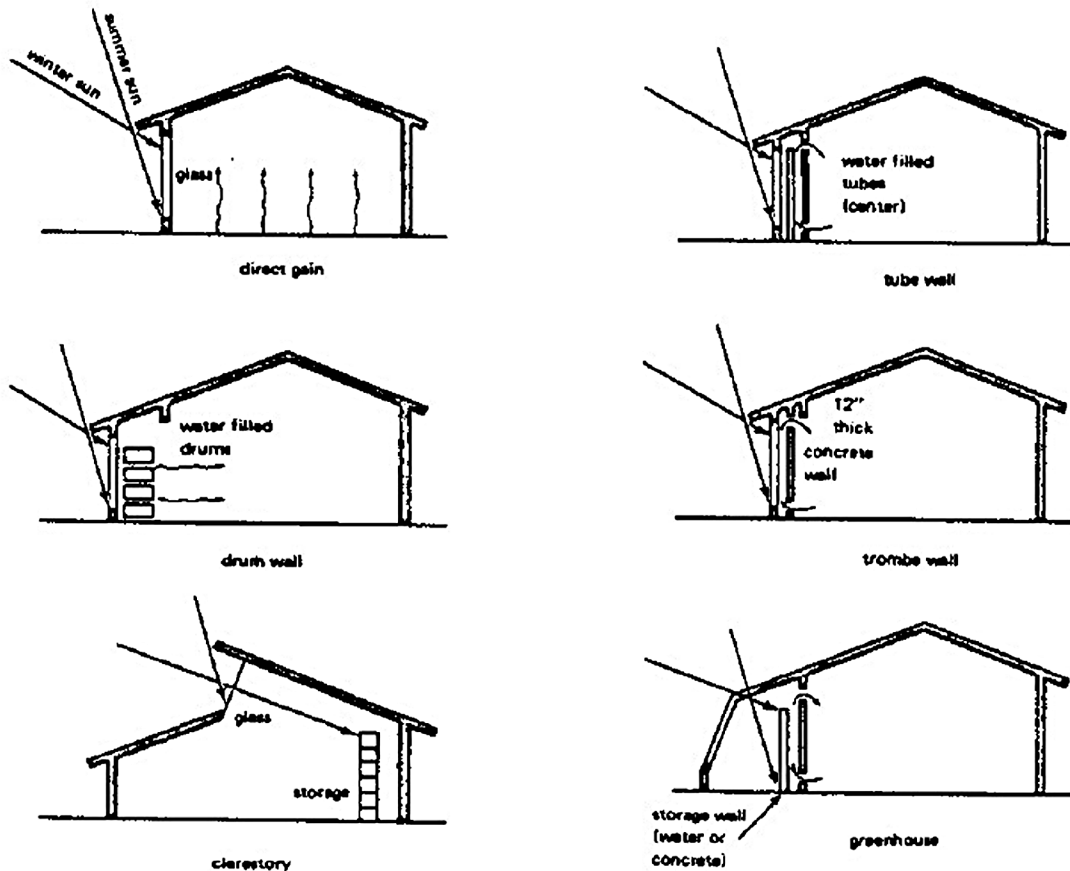
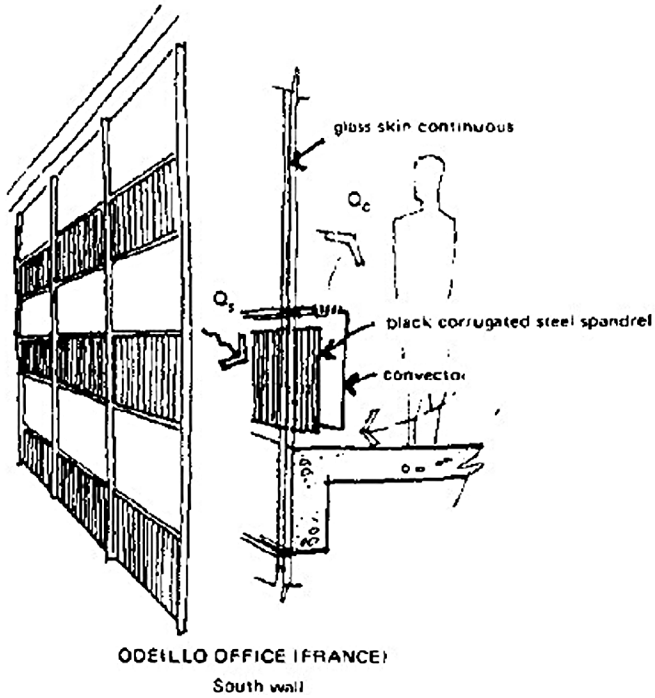

Figure 2-19  
Passive solar energy systems

state performance. This problem has been overcome in at least one installation by the use of a cold storage unit. The cold storage unit permits continuous operation of the absorption cooler and thus allows some reduction in the system and cooler size. A fourth consideration is the need for some means of cooling the absorber and the condenser. A cooling tower or some other low temperature cooling system must be used to obtain reasonable performance. All of the commercially available units require a cooling tower which is another maintenance item. Current research is underway to develop units that do not have a separate cooling tower.

**2.7.2 RANKINE CYCLE HEAT ENGINE COOLING.** Rankine cooling systems are still in development with only a few in operation. In these systems the shaft power produced

by a heat engine drives the compressor in a conventional vapor compression-type cooling machine. The thermal energy input to the heat engine can be from a solar collector or from a solar collector and a fossil fuel combustor. The fossil fuel can supplement solar energy, or it can be used alone as the auxiliary energy supply when no solar energy is available. Alternatively, electricity can be used as the auxiliary energy supply by coupling an electric motor directly to the compressor shaft. Another option is a motor-generator using a heat engine for generating electricity when solar energy is available and there is little or no cooling load. From state-of-the-art considerations, two types of fluid heat engines are primarily feasible in solar cooling units. In one type of engine, the working fluid cyclically changes phase from liquid to gas and back to liquid. The most widely used engine of this type operates on the Rankine cycle. In the other type, the working fluid remains in the gaseous state. These engines operate on various cycles, including the Stirling and Brayton cycles. For relatively low thermal energy input temperatures (less than 400 deg. F), Rankine cycle engines are superior in performance to gas cycle engines. At higher temperatures, gas cycle engines equal or better the performance of Rankine cycle engines. Relatively low temperatures are attainable with state-of-the-art thermal solar collectors, so the heat engine-vapor compression development projects involve Rankine cycle engines. In a Rankine cycle engine, fluid in the liquid state is pumped into a boiler where it is evaporated and possibly superheated by thermal energy. The vapor generated in the boiler is then expanded through a device such as a turbine, a piston-cylinder (reciprocating) expander, or a rotary vane expander. The expansion process lowers the temperature and pressure of the vapor, and effects a conversion of thermal energy into shaft work. The fluid leaves the expander either in the vapor phase or as a liquid-vapor mixture and flows into a condenser, where it returns to the liquid phase by giving the energy of condensation to cooling water or ambient air. This liquid is then pumped into the boiler, and the cycle is repeated. In some systems under development, the same working fluid is used in both the Rankine engine and the vapor compression chiller, which permits the use of common condenser and the elimination of special seals to maintain fluid separation in the expander-compressor unit. These systems have areas that need development in matching the solar heat engine with the mechanical compressor units of



New construction - office  
passive system

**Approach**

air collector for buildings;  
used during day only

**Operation**

natural (convective)  
transfer of solar Q to building Q

**Advantages**

- Operative during building use period - thus no storage
- Simple, no moving parts
- Effective in ideal climate

**Problems**

- night operation

Figure 2-20

New construction (office) passive solar energy system

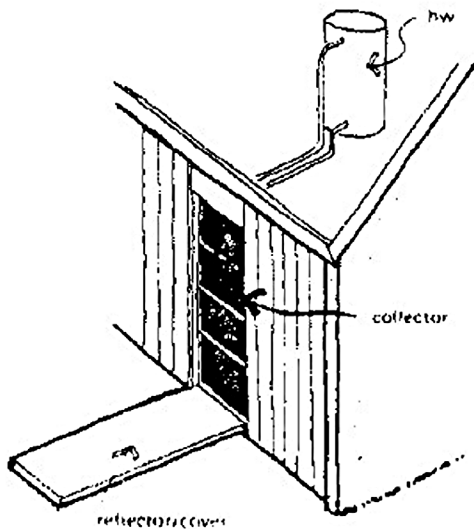

Thermosyphon DHW System

wall (vertical) collector close  
cover each night-avoid drain  
requirement. Adjust reflector  
for season.

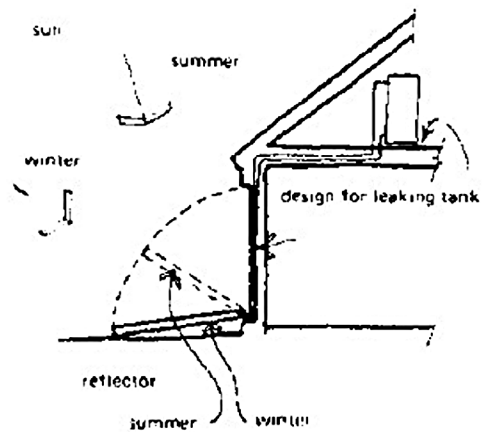
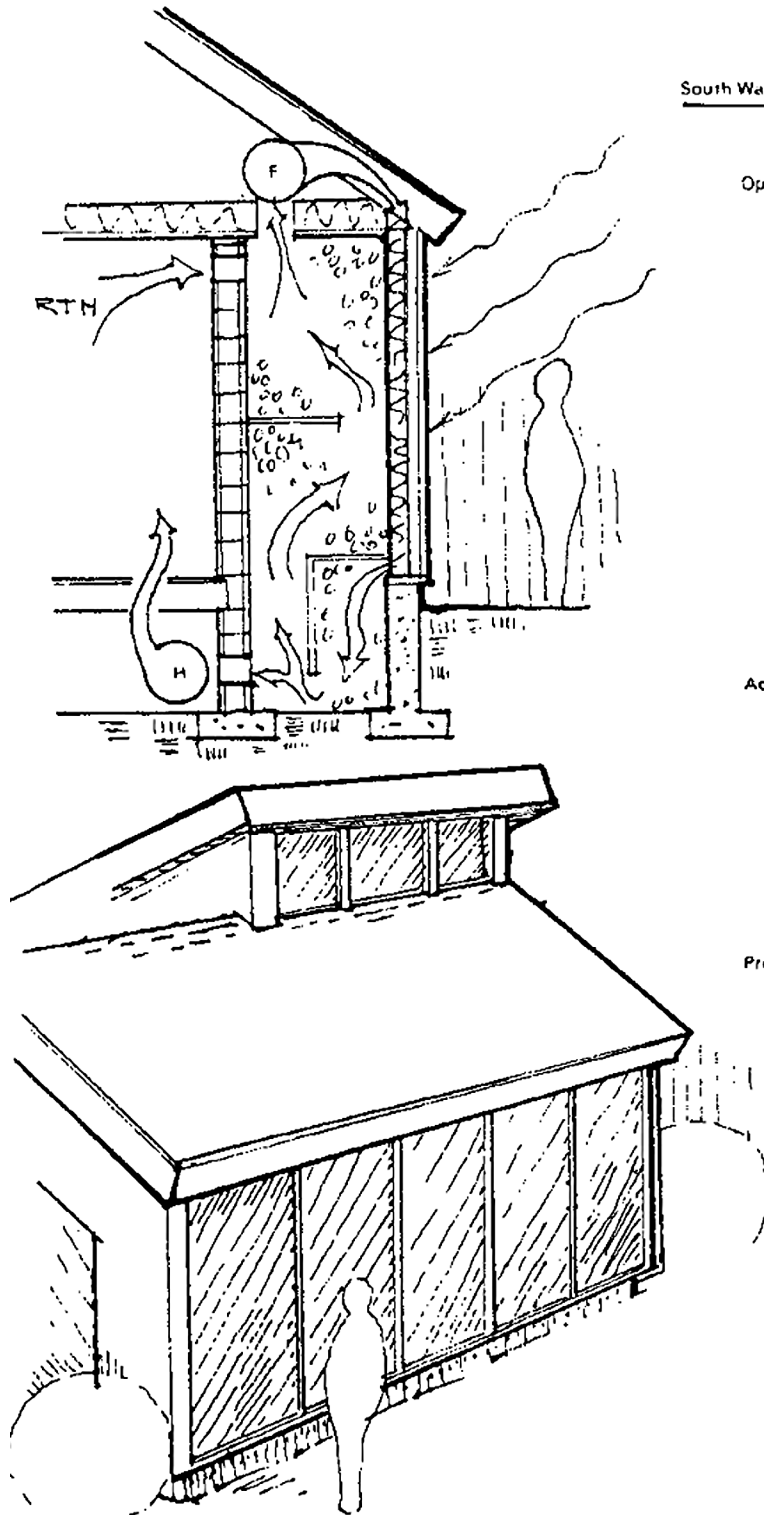

Figure 2-21

Vertical wall solar collector

South Wall Collector With Combined Storage



**Operation**

Rock storage is located directly behind collector

Direct recirculation of air from collector to storage

Collector is vertical

Conventional hot air heater

Takes suction on storage.

During normal solar operation, hot air from storage would be blown into house duct distrib. system. When storage temp. is too low, heater will come on to take over heating load.

Limited summer cooling can be obtained by circ. cool night air through rock bed

**Advantages**

Minimizes heat loss from the air moving between storage and collector by eliminating duct runs

Reduces cost of construction by incorporating both collector and storage as structural elements in the house

**Problems**

Some loss of efficiency by use of a vertical collector

Potential shading problem from nearby trees or structures

Figure 2-22

South wall solar collector with combined storage

## Retrofit With Large Rock Storage

### Operation

Hot air from collector is circulated through large rock storage under insulating berm.

Room air is circulated in reverse direction through the rock bed to heat air for the house.

Under optimum conditions, large storage may allow 100% solar heat.

Retrofit shown can be applied to the south face of any building. Two story application shown allows maximum room for collector and storage.

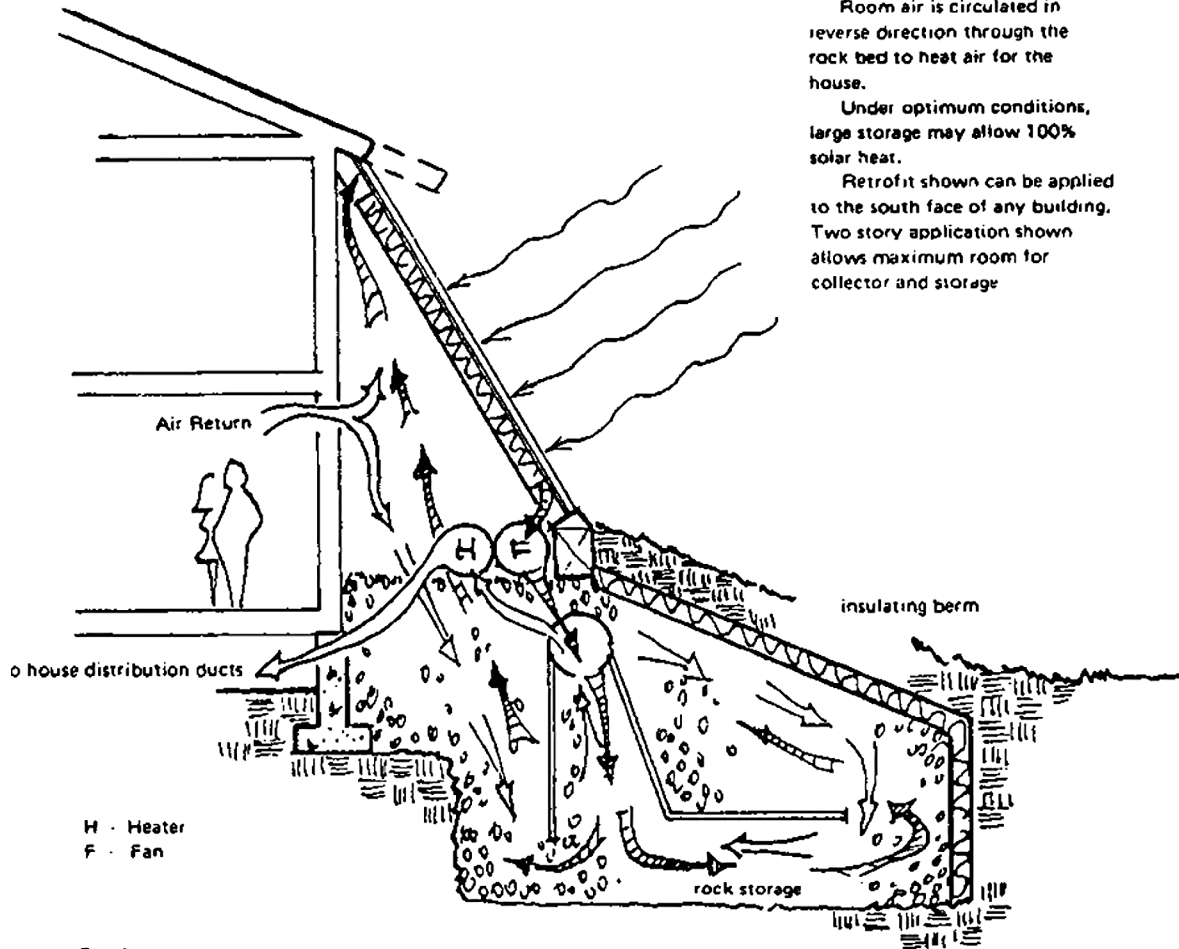

### Problems

- Solar water heating would require a second heat exchanger at extra expense.
- Ground position of collector may be shaded by trees or buildings.
- High water table would interfere with storage.
- Large amounts of rock may be expensive at some building sites.

### Advantages

- Excavation and backfill over the rock provides a low cost, well insulated containment for storage.

Figure 2-23  
Retrofitted large rock bin storage



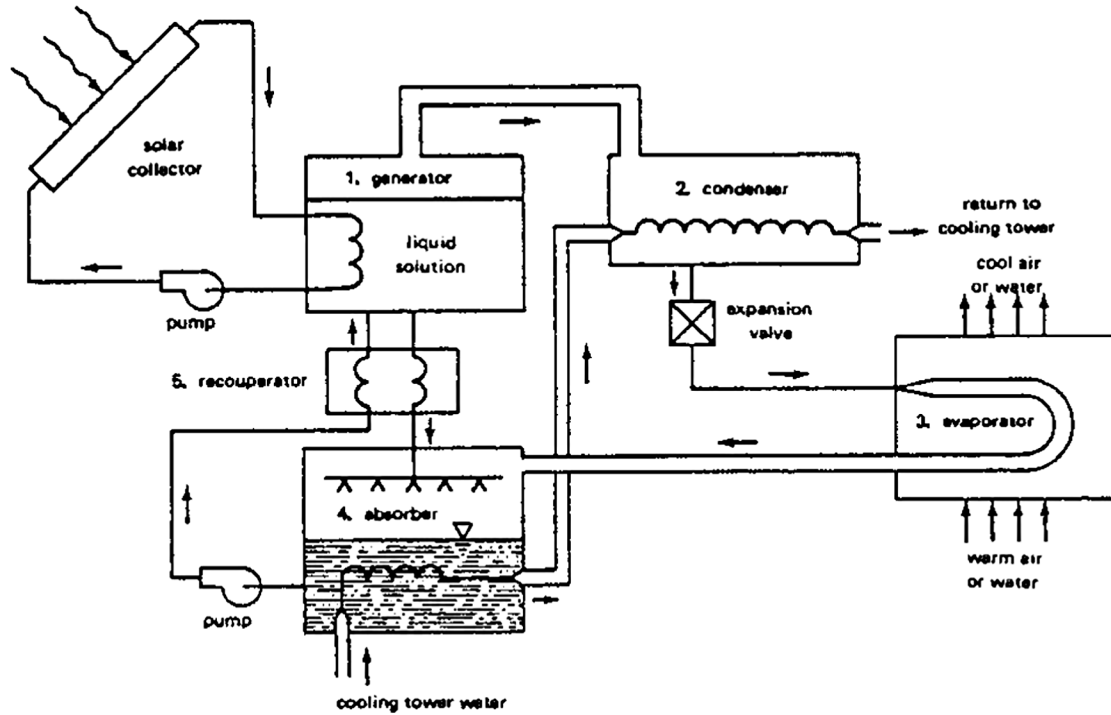

Figure 2-24

Schematic of lithium bromide absorption cooler

the cooling equipment. Since most compressors are designed for certain speed and torque inputs, the varying operation of a solar heat engine will probably reduce the overall COP of the unit. Also the solar heat engine is at high efficiency at high storage tank temperatures whereas the solar collectors are at low efficiency which will also affect the COP of the system. These systems are designed for large cooling load applications.

**2.7.3 DESICCANT COOLING.** The Rankine engine vapor compression and the absorption cooling units operate on the basis of closed cycles-fixed amounts of working fluid are circulated within sealed equipment; the working fluids do not come in contact with the building air. Desiccant cooling systems, on the other hand, may be designed for open-cycle operation, since the only circulating fluids involved are air and water. The basic concept is to dehumidify air with a desiccant, evaporatively cool the dehumidified air, and regenerate the desiccant with solar-derived thermal energy. Two basic open-

cycle arrangements are feasible: the ventilation mode and the recirculation mode. In the ventilation mode, fresh air is continually introduced into the conditioned space. In the recirculation mode, exhaust air from the conditioned space is reconditioned and returned to the space. Figure 2-25 illustrates a ventilation system in which a solid desiccant material mounted on a slowly rotating wheel provides the basis for obtaining a cooling effect.

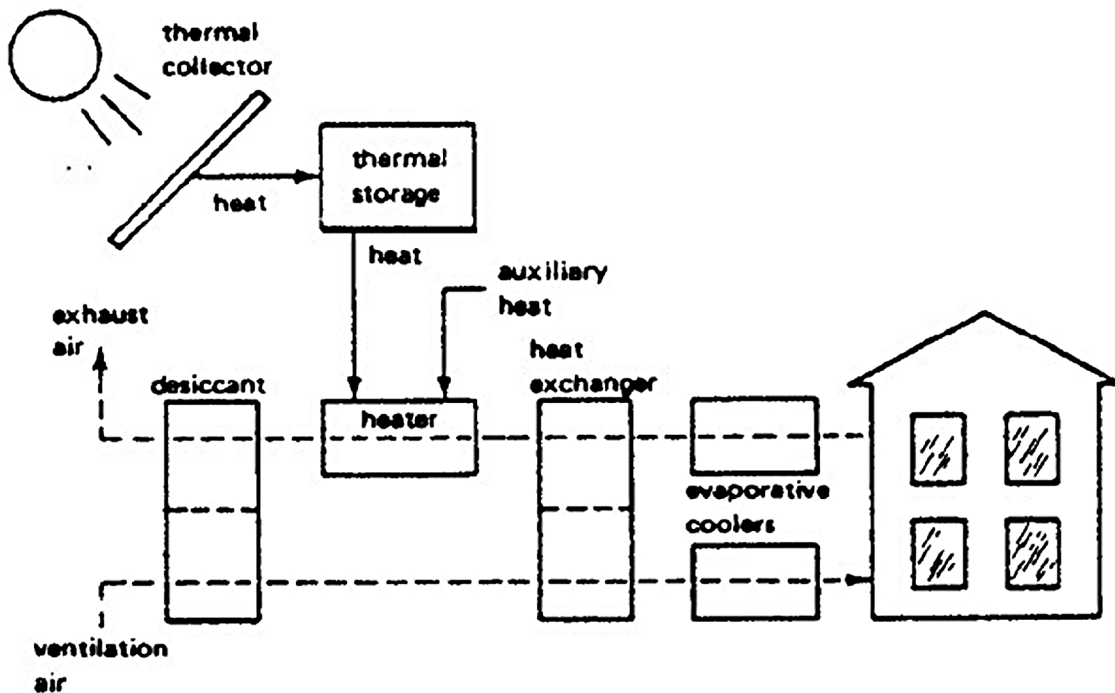

Figure 2-25  
Schematic of solar desiccant cooling

The hot desiccant material absorbs moisture from incoming ventilation air and increases the dry-bulb temperature. This dry air stream is cooled in two steps. First, it is sensibly cooled by heat exchange with the building exhaust air. Then it is evaporatively cooled and partially rehumidified by contact with a water spray. The exhaust air from the building is evaporatively cooled to improve the performance of the heat exchanger. After being heated by heat exchange with the incoming air, the exhaust air is further heated by energy from the solar system and/or from an auxiliary energy source. The hot exhaust air passes through the desiccant material and desorbs moisture from it, thereby

regenerating it for continuation of the process. Desiccant systems have faced problems of high parasitic power and large space requirements relative to capacity. Because of their bulkiness, the systems may have primary application in the low capacity range (i.e., residential systems) if and when ways can be found to reduce parasitic power requirements to acceptable levels. The Institute of Gas Technology (IGT) has been investigating design modifications in a prototype 3-ton system. AiResearch is developing a 1-1/2-ton desiccant cooling system around a radial flow design. Illinois Institute of Technology is developing a dehumidifier of a cross-flow design that will provide more compact and efficient operation than previous designs. Zeopower is developing a unique closed cycle desiccant system in which the desiccant is integral with the collector.

**2.7.4 OTHER COOLING METHODS.** Other methods, using solar heating equipment but not direct solar energy, should also be considered. These methods chill the thermal storage unit of the system during the night and use the chilled medium to provide the daily cooling load. Methods of chilling the storage include radiation of the heat to the night sky and heat exchange with the night air cooled or uncooled by auxiliary means. The chilled storage is used directly, via heat exchange with the building air. Both rockbed and water storage are suitable since the only additional hardware required is that to route the fluid. A heat pump can be used during the day to cool the building and reject heat to the thermal storage unit. The thermal storage is then cooled by using the solar collectors for night sky radiation. From experimentation in Arizona, Bliss obtained a nightly heat rejection quantity of 360 Btu/night/ft<sup>2</sup> for a black cloth radiator. Analytical estimates can be obtained using an effective clear sky temperature of 25 deg. F (14 deg. C) lower than the ambient air temperature. The advantage of this system is that the same equipment (collectors and heat pump) can also be used for heating. In systems with dual storage units, the heat pump transfers heat from one to the other - cooling the first and warming the second. The cool fluid in the first unit is circulated to the house while the concentrated heat in the second is discharged to the outdoors. An evaporative cooler can be used coupled with a rockbed storage unit. Night air is evaporatively cooled and circulated through the rockbed to cool down the pebbles in the

storage unit. During the day, warm air from the building can be cooled by passing it through the cool pebble bed. This method is not very effective in humid geographical areas. The storage volume can also be cooled using a small refrigeration compressor. Most through-the-wall air conditioners use such compressors to cool the indoor air. This unit acts as the backup or auxiliary cooling system - analogous to the backup heating system. If operated only at night, its capacity can be as small as half that of an independently functioning unit and still meet peak cooling demands. Nighttime operation will be particularly wise if electric companies charge more for electricity during times of peak loads on hot summer afternoons. An even smaller compressor can be used if it operates continuously night and day - cooling the storage when not needed by the house.

**2.7.5 ESTIMATING SYSTEM SIZE.** The sizing of cooling system components is dependent on hardware, climate, and economic constraints. The cooling unit must be sized so as to provide the maximum cooling load under conceivable adverse conditions of high humidity and low or erratic solar insolation. The collection area required is dependent on the fraction of the cooling load to be provided by solar. Very large collector areas may be required for 100% solar cooling under adverse conditions of high humidity and low insolation. Although a detailed calculation method, as provided in the worksheets in the following sections for heating systems, is not available for solar cooling, an estimate of the required collector area can be made by the equation:

$$A = (\text{Cooling load}/\text{COP})/ (I_T \times [\eta]_{\text{collect}} \times [\eta]_{\text{delivery}})$$

where: Cooling load = the portion of the total cooling load provided by solar calculated using ASHRAE techniques or others.

COP = Coefficient of Performance of the cooling unit. COP is the ratio of heat energy removed to energy supplied from external sources. Manufacturing data is recommended for determining COP (3413 Btu = 1 kWh).

$I_T$  = average instantaneous solar insolation on collector surface (i.e., at tilt angle).

$[\eta]_{\text{collect}}$  = average collector efficiency under design conditions.

$[\eta]_{\text{delivery}}$  = delivery efficiency which takes into account heat exchanger efficiency and thermal losses.

In general, the collector area required to provide the majority of the cooling load is larger than the collector area of typically sized heating only systems. Collector areas for heat engine systems are larger than the areas for absorption cooling systems due to the thermal efficiency of the heat engine, which should be included in the preceding equation.

**2.8 SYSTEM CONTROLS.** System controls are used to turn on a circulating pump or blower to the collector only when the sun is providing heat. Differential thermostats are commercially available to turn on the collector pump only when the collector plate temperature is a preset number (usually 20 deg. F) hotter than the storage tank bottom temperature. A typical control strategy is shown in Figure 2-26 (Rho-Sigma, undated) and the hookup in Figure 2-27. Differential thermostats are available with high temperature protection and low temperature (freeze) protection. High temperature protection is important, especially in evacuated tube collectors, in that it prevents a very "hot" collector from suddenly receiving a supply of cold water thus producing a thermal shock that could damage the collector components. Another type of control called proportional control is available. It is similar to the ON/OFF differential controller in operation. The difference is that the proportional controller changes the threshold ON and OFF points and controls the flow such that less than full flow can be achieved if the sun is at less than full intensity. The advantage is that the proportional control can "turn on" the system when the other controller (the ON/OFF type) is waiting for more sun to become available. This is an advantage on cloudy days and early morning start ups. Overall system efficiency is increased slightly with the proportional control. These

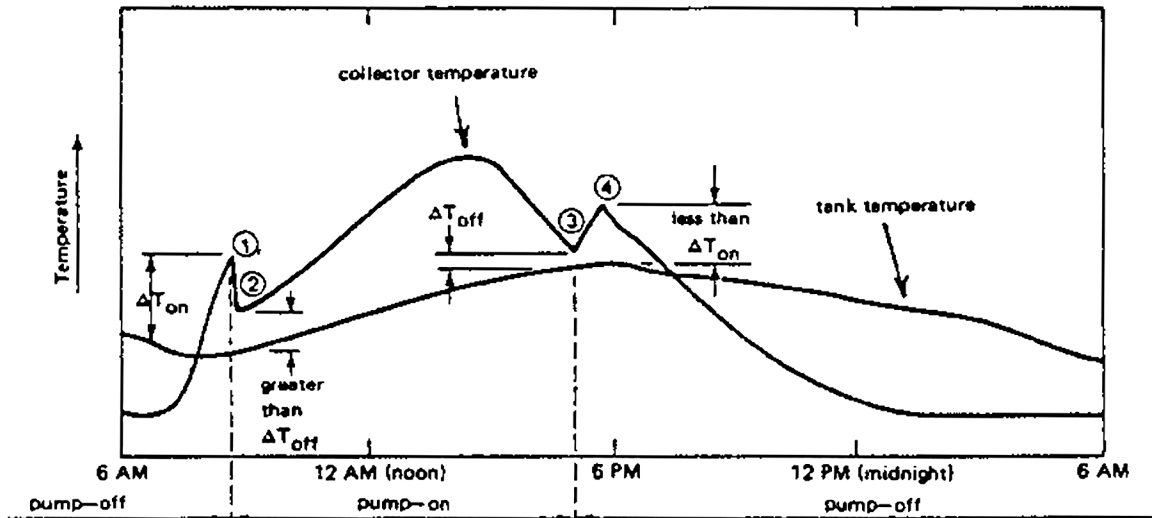

Figure 2-26  
Control system strategy

controls are more expensive and one such experiment at NCEL has shown that proportional controls result in considerably more cycling of the pump motor which could shorten pump life. It is recommended that the control manufacturer be consulted on this point before a proportional control is used. As the building requires heat, other controls must direct pumps or blowers to provide heat from the storage tank to the load. This control is the conventional thermostat. The same room thermostat may control the auxiliary heater; however, a delay timer or a two-step room thermostat must be incorporated into the auxiliary heater control circuit so that the auxiliary heat will not come on if heat is available from storage. Ten minutes has been suggested as a typical time delay before auxiliary heat comes on. Some manufacturers supply combination thermostat and solar system controls.

## 2.9 PIPING, PUMPS, VALVES.

**2.9.1 PIPE AND HEADER SIZING.** Piping should be designed for low pressure drop. All exposed piping should be well insulated with approved weather resistant insulation. Dielectric unions should be used at connections between dissimilar metals.

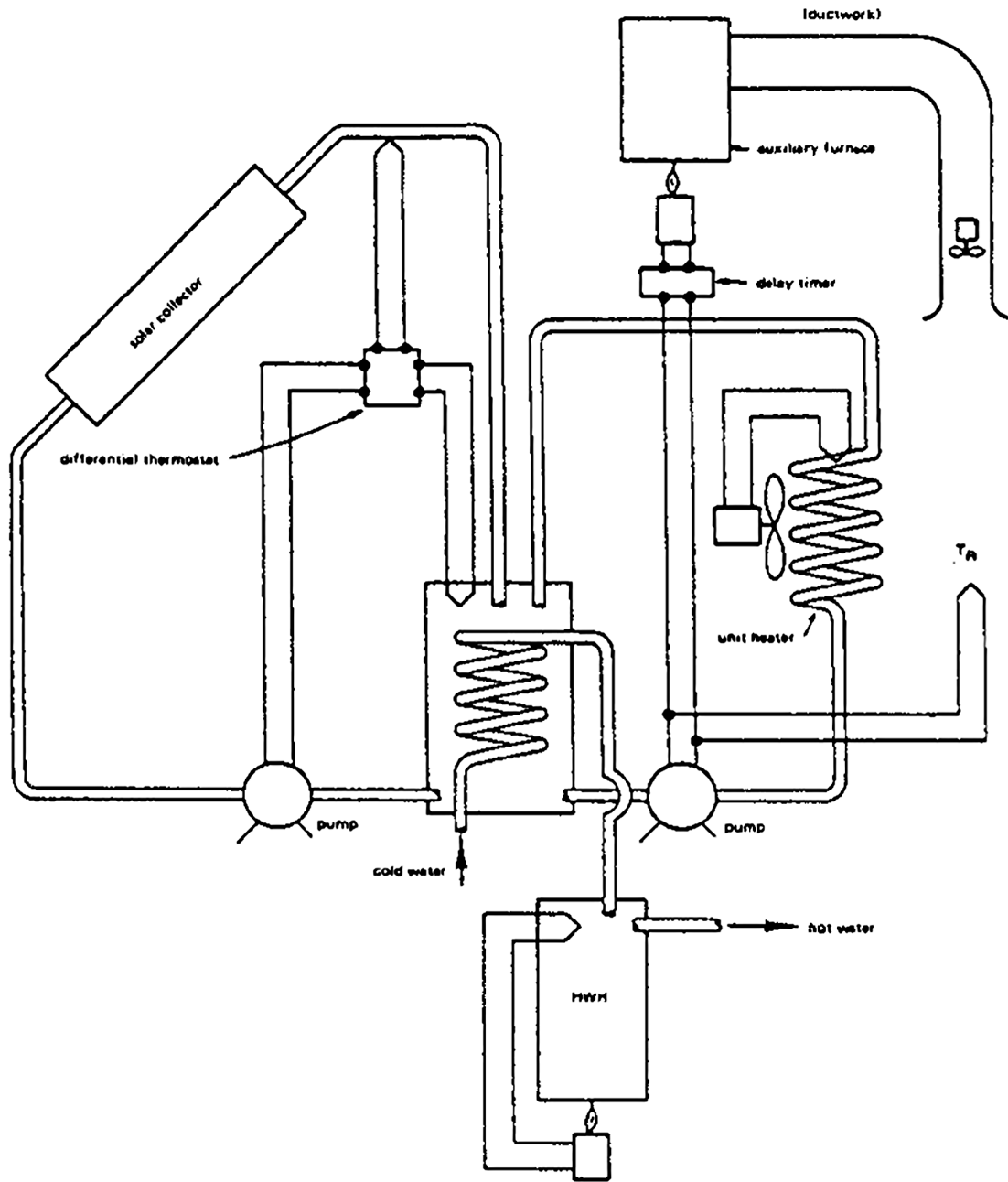

Figure 2-27  
Control of system for space and DHW heating

Rubber or silicone hose used for connections must be of a high temperature type. The pipe ends should have ferrules to provide a good seal with the hose. In low pressure systems, spring type clamps are preferred because they compensate for thermal expansion. Copper pipe is preferred to galvanized steel due to its longer life expectancy and relative ease of installation. Thermal expansion should be provided for all piping or hard tubing. Pipe sizing should be in accordance with recognized methods, but for most installations the following estimates are reasonable:

- For a single row of parallel collectors with "X" number of branches, 0.5 gpm flow per collector, water or 50% glycol as heat transfer fluid.
  - Up to 3 collectors - 1/2-inch headers
  - 4 to 7 collectors - 3/4-inch headers
  - 8 to 12 collectors - 1-inch headers
  - 13 to 18 collectors - 1-1/4-inch headers
  - More than 19 collectors - 1-1/2-inch or larger (size for each design)
- b. Same as above except collectors in a double row series-parallel arrangement.
  - Up to 5 collector branches - 1/2-inch headers
  - 6 to 10 collector branches - 3/4-inch headers
  - 11 to 15 collector branches - 1-inch headers
  - 16 to 22 collector branches - 1-1/4-inch headers
  - More than 23 collectors - 1-1/2-inch or larger (size for each design)

**2.9.2 PUMPS AND COLLECTOR FLOWRATE.** Pumps are sized in accordance with recognized practices also. Since solar systems are nothing more than a combination of pipes, valves, and fittings it is possible to do a heat loss calculation to determine the system head. Charts are available in standard fluid flow handbooks that give the friction losses or "equivalent length of feet in pipe" for various fittings and valves. These are merely summed for the entire system. The flowrate through the collector loop is determined by the maximum amount of energy which must be removed from the collector. This maximum is about 225 Btu/ft<sup>2</sup>/hr. Often a manufacturer will specify the flowrate through his collector and this value should be used. If not, an estimate can be made by determining the flowrate necessary to remove the maximum amount of energy



while minimizing the collector inlet temperature (to maintain high collector efficiency). The rule of thumb for this calculation is 0.015 to 0.020 gpm for each square foot of collector area for water. For other fluids this can be scaled by the value of the specific heat of the fluid as compared to water ( $C_U = 1$  Btu/lbm-deg. F). Now that head loss and flowrate are determined, a pump can be selected by using the manufacturers' standard tables and graphs. For typical domestic hot water systems and space heating systems for a house for a family of four, the pumps are quite small, averaging 1/12 to 1/20 hp. In some systems, like a drain down system, pump sizes can be much larger due to the higher vertical "head" requirements. If the water in the system is open to the atmosphere or if the water is to be used for drinking the pump should be made of bronze or stainless steel on all water-wetted surfaces to minimize corrosion. Pumps will have longer life if they are placed in low temperature parts of the water circuits. Pumps can be "staged" to give more flow or head. Two pumps in series will give the same flow against twice the head. Two pumps in parallel will give twice the flow at the same head. Two or more small circulator-type pumps are often cheaper than a single larger pump.

**2.9.3 VALVES.** Valves, other than seasonal or emergency shut-off valves, should be electrically operated and located out of the weather or well protected. A vent must be provided at the high point in liquid systems to eliminate entrapped air and it should also serve as a vacuum breaker to allow draining of the system. To avoid multiple venting, systems should be piped to avoid having more than one high point. Pressure relief must be provided at some point in each flow circuit. Check valves can be added to prevent thermally induced gravity circulation. A flow-check valve (used in the hydronic heating industry) will also accomplish the same purpose. Mixing valves should be used to protect DHW systems from delivering water hotter than specified (usually 120 deg. - 140 deg. F). Consideration should be given to energy conservation by lowering DHW temperature whenever possible. Often 105 deg.-115 deg. F will suffice if water is used only for showers and washing hands.

## **2.10 OTHER CONSIDERATIONS.**

**2.10.1 ARCHITECTURAL.** Solar collector arrangements should be studied to facilitate blending collector panels into the architecture of new or existing buildings. Shade trees must be so located as not to cast shadows on the collector. Other structures such as chimneys which can cast shadows should be carefully located to avoid shading of the collector. Experience of Florida installers indicates that if collectors are placed directly on the roof, the life of asphalt shingles under the collector may be reduced by up to 50%. This suggests that a small space should be left between the collector and the roof, or the collector should be built into the roof. In the latter case, the design must provide for simple glass replacement. A space between collector and roof allows for snow to fall through rather than accumulate.

**2.10.2 REDUCTION OF HEAT LOSSES.** Reduction of heat losses is usually one of the most important steps in the design of a solar space heating system. It almost always costs less to super-insulate a building to reduce losses than to provide additional solar collector area to provide the extra heat. Installing 12 or more inches of insulation in the attic, insulating existing walls by injecting nonflammable foam (one manufacturer claims 30% reduction in total heat loss, multiple glazing, and weatherstripping should all be evaluated for cost effectiveness versus a larger solar system. If the solar-augmented system is found to be cost competitive with a conventional system on a life cycle cost basis, then the cost effective amount of insulation will be the same for both the solar and conventional systems. Thus the solar system should not be charged for the cost of insulating the house.

**2.10.3 MAINTENANCE AND ACCESSIBILITY.** Systems should be designed for minimum maintenance. Maintenance of glass will be minimized if vandalism can be reduced. Collectors of flat-roofed buildings may be shielded from the ground by a skirt around the roof perimeter. Locating the collector in the backyard area of residences rather than on a street-facing roof reduces probability of vandalism. Double strength glass for top surface can be used in hail areas, and also provides protection from small stones. Still more protection is offered by a screen of 0.5-inch mesh stretched several inches above the collectors, but with some loss in collector efficiency (15%). Generally

mesh screens are not recommended. Collectors and mounts must withstand expected wind and snow loads. Collector design should allow for rapid replacement of glass covers. Pumps, pipes, and controls should be reasonably accessible to allow repair or replacement. Water pumps should be located so that leakage does not cause serious damage. As solar designs move from theory to practice, a knowledge of reliability, durability, and maintainability is desired to achieve maximum system performance. To achieve this information NCEL has initiated an on-site evaluation of solar systems. These evaluations have resulted in a compilation of "lessons learned" which in turn has resulted in suggestions as to how to do a preventative maintenance program to avoid these common problems. The list of "lessons learned" can be used as a pre-design checklist as well as a guide for a preventative maintenance program.

# QUIZ

## **An Introduction to Solar Collectors for Heating and Cooling of Buildings and Domestic Hot Water**

1. Some collectors are manufactured with a black coating which absorbs the high frequency incoming solar radiation very well and which emits low frequency infrared radiation poorly. This is a highly desirable combination of properties for a collector. The absorptance should be \_\_\_\_\_ or higher and emittance may be 0.1 or lower. Such coatings are approximately equal in effect to one cover glass.

- a. 0.9
- b. 0.8
- c. 0.7
- d. 0.6

2. The transparent covers on solar collectors serve to admit solar radiation to the absorber while reducing \_\_\_\_\_ and radiation heat losses from the collector.

- a. ultra violet
- b. conduction
- c. convection
- d. osmotic

3. For all year domestic hot water (DHW) heating systems, a collector tilt angle equal to the \_\_\_\_\_ is recommended.

- a. latitude
- b. longitude
- c. collector area
- d. collector capacity

4. For all year DHW heating and winter space heating, use a collector tilt angle equal to the latitude plus \_\_\_\_\_ degrees.

- a. 10 to 15
- b. 15 to 20
- c. 20 to 25
- d. 25 to 30

5. For summer space cooling use a tilt angle equal to the latitude minus \_\_\_\_\_ degrees.

- a. 15 to 20
- b. 10 to 15
- c. 5 to 10
- d. 0 to 5

6. Energy from the sun is received by the earth only as \_\_\_\_\_ radiation.

- a. ultra violet
- b. electromagnetic
- c. infrared
- d. X-band

7. The "greenhouse effect" refers to the ability of glass to transmit visible radiation but prevent the loss of heat from the collector plate which radiates at \_\_\_\_\_ wavelengths.

- a. coherent
- b. shorter
- c. longer
- d. all of the above

8. Even though solar collectors can collect heat from the diffuse component of solar radiation, solar systems are designed to use the direct component. Direct radiation is in the form of \_\_\_\_\_ rays coming straight from the sun.

- a. parallel
- b. serial
- c. global
- d. focused

9. Collectors of primary interest for space and water heating are of two basic types: liquid and air. Liquids may be \_\_\_\_\_, an antifreeze mixture, or various hydrocarbon and silicone heat transfer oils.

- a. paraffins
- b. miscible fluids
- c. fluorocarbons
- d. water

10. Flat-plate collectors are most suitable for \_\_\_\_\_ temperature applications such as domestic hot water and space heating.

- a. high
- b. medium
- c. low
- d. adjustable

11. Solar collectors of primary interest for space and water heating are of two basic types: liquid and \_\_\_\_\_.

- a. solid
- b. air
- c. carbon
- d. hydrogen

12. One or more transparent covers are provided on solar collectors to reduce thermal losses by radiation and by \_\_\_\_\_ .

- a. indirection
- b. direction
- c. conduction
- d. convection

13. \_\_\_\_\_ collectors are most suitable for low temperature applications such as domestic hot water and space heating.

- a. Focused
- b. Concentrating
- c. Flat-plate
- d. Indirect

14. Solar collectors are usually manufactured with a black coating which absorbs the high frequency incoming solar radiation very well and which emits low frequency infrared radiation poorly. This is a highly desirable combination of properties for a collector. The absorptance should be \_\_\_\_\_ or higher and emittance may be 0.1 or lower.

- a. 0.9
- b. 0.8
- c. 0.7
- d. 0.6

15. The transparent covers on flat plate solar collectors serve to admit solar radiation to the absorber while reducing \_\_\_\_\_ and radiation heat losses from the collector.

- a. transmission
- b. conduction
- c. convection
- d. counterflow

16. Insulation behind and to the side of a solar collector absorber serves to reduce conduction losses. Usually, this insulation consists of 1 to \_\_\_\_\_ inches of high-temperature fiberglass batting or semi-rigid board or even mineral wool.

- a. 3
- b. 4
- c. 5
- d. 6

17. The housing or collector box of a solar collector serves to support the collector components, protect the absorber and insulation from the environment, and reduce convection and \_\_\_\_\_ losses from the absorber.

- a. conduction
- b. radiation
- c. thermal
- d. counterflow

18. The use of water as a collector fluid has two serious drawbacks: it freezes and it \_\_\_\_\_ .

- a. has a low specific gravity
- b. boils at an unacceptably low temperature
- c. evaporates
- d. can cause corrosion

19. One way of preventing freezing of the collector fluid is the \_\_\_\_\_ method.

- a. drain down
- b. constant flow
- c. variable volume
- d. perforated collector

20. A disadvantage of the recirculation method for preventing freeze damage is that \_\_\_\_\_ is reduced because warm water from storage is used to maintain circulating water at an adequate temperature.

- a. circulation
- b. thermal efficiency
- c. fluid velocity
- d. fluid output

21. The main drawback of silicone fluids as collector fluids is their \_\_\_\_\_.

- a. flash point
- b. cost
- c. low specific gravity
- d. corrosivity

22. The U.S. Department of Housing and Urban Development (HUD) minimum property standards for collector fluids for solar heating systems recommends a closed-cup flashpoint \_\_\_\_\_ deg. F higher than maximum expected collector temperatures.

- a. 25
- b. 50
- c. 75
- d. 100

23. Water flow through \_\_\_\_\_ collectors should always be against gravity, except in trickle-type collectors.

- a. serial
- b. horizontal
- c. non-horizontal
- d. parallel

24. The three most common types of solar collectors are flat plate collectors, \_\_\_\_\_ collectors, and concentrating collectors.

- a. parallel
- b. counterflow
- c. evacuated tube
- d. rack and tube



25. The most popular types of concentrating collectors are the parabolic trough, the linear-trough fresnel lens, and the \_\_\_\_\_ .

- a. double tube array
- b. focused lens
- c. compound parabolic mirror
- d. non-linear mirror

26. For typical family residences, \_\_\_\_\_ gal/day/person of domestic hot water is normally consumed.

- a. 10
- b. 20
- c. 30
- d. 40

27. A variation of the domestic hot water (DHW) system is the \_\_\_\_\_ system which uses the principle of natural convection of fluid between a collector and an elevated storage tank.

- a. elevated tank
- b. convection
- c. thermosyphon
- d. conduction

28. A solar-powered hot water space heating system is a simple extension of the \_\_\_\_\_ system.

- a. domestic hot water
- b. forced air heating
- c. package HVAC
- d. domestic water

29. A \_\_\_\_\_ is an option for heat storage.

- a. lined collector
- b. counterflow heat exchanger
- c. focused lens
- d. rock bed

30. In a hydronic heating system, most baseboard heaters have comparatively small surface areas, so they require higher temperatures, typically about \_\_\_\_\_ degrees, F.

- a. 160
- b. 170
- c. 180
- d. 190

31. In an air-type solar heating system, the \_\_\_\_\_ of the liquid-type system are replaced by air ducts and fans.

- a. pipes and pumps
- b. collectors
- c. storage tanks
- d. solar concentrators

32. The ability to circulate building air directly through the \_\_\_\_\_ is one of the major advantages of an air-type solar space heating system.

- a. heat exchanger
- b. storage tank
- c. collectors
- d. unoccupied spaces

33. Some air-to-air heat pumps function very well as an auxiliary heater at temperatures down to \_\_\_\_\_ degrees F.

- a. 20
- b. 30
- c. 40
- d. 50

34. A liquid-to-air heat pump is an ideal auxiliary heater when coupled with liquid solar storage. It greatly enhances solar energy collection by drawing down the temperature of the solar storage water to as low as \_\_\_\_\_ deg. F.

- a. 45
- b. 40
- c. 35
- d. 30

35. In passive solar heating design, south-facing passive storage walls in direct sunlight should have a minimum of 30-lb water storage or \_\_\_\_\_-lb masonry (concrete) storage per square foot of south vertical glazing.

- a. 125
- b. 150
- c. 175
- d. 200

36. In passive solar heating design, shading of south windows should be used to reduce summer and fall overheating. One effective geometry is a roof overhang which will just shade the top of the window at noon (solar time) sun elevation of 45 deg. and will fully shade the window at noon sun elevation of \_\_\_\_\_ deg. F.

- a. 85
- b. 78
- c. 71
- d. 64

37. In passive solar heating design, the best thickness of a Trombe wall is from \_\_\_\_\_ inches.

- a. 24 to 28
- b. 20 to 24
- c. 16 to 20
- d. 12 to 16

38. In passive solar heating design, a rule-of-thumb for a well-insulated space in 40 deg. N latitude in cold climates (outdoor temperature = 20 deg. F to 30 deg. F) the ratio of south glazing to floor area is in the range \_\_\_\_\_ to maintain an average space temperature of 68 deg. F over 24 hours.

- a. 0.30 to 0.35
- b. 0.25 to 0.30
- c. 0.20 to 0.25
- d. 0.15 to 0.20

39. \_\_\_\_\_ cooling is the most commonly used method of solar cooling.

- a. Absorption
- b. Evaporative
- c. Variable air volume
- d. Terminal reheat

40. A/An \_\_\_\_\_ refrigeration machine is basically a vapor-compression machine that accomplishes cooling by expansion of a liquid refrigerant under reduced pressure and temperature, similar in principle to an ordinary electrically operated vapor-compression air conditioner.

- a. evaporative
- b. reverse osmosis
- c. absorption
- d. miscible fluid

41. \_\_\_\_\_ cooling systems are still in development with only a few in operation.

- a. Hazen-Williams
- b. Ammonia-water
- c. Lithium-bromide
- d. Rankine

42 . \_\_\_\_\_ cooling systems may be designed for open-cycle operation, since the only circulating fluids involved are air and water. The basic concept is to dehumidify air with a desiccant, evaporatively cool the dehumidified air, and regenerate the desiccant with solar-derived thermal energy.

- a. Desiccant
- b. Rankine
- c. Coulomb
- d. Lithium-bromide

43. For a single row of 10 parallel collectors with 0.5 gpm heat transfer water flow per collector, the recommended header pipe size is \_\_\_\_\_ .

- a. 2-inch
- b. 1.5 inch
- c. 1.25-inch
- d. 1-inch

44. It almost always costs less to \_\_\_\_\_ building to reduce losses than to provide additional solar collector area to provide the extra heat.

- a. super-insulate a
- b. increase ventilation to
- c. increase fenestration in a
- d. provide supplemental heat in a

45. Experience of Florida installers indicates that if collectors are placed directly on the roof, the life of asphalt shingles under the collector may be reduced by up to \_\_\_\_\_

- a. 60%
- b. 50%
- c. 40%
- d. 30%